



Product & Packaging Specs

Wood to Wood Bracket (W2W-FB)

Item #: 50120

ITEM NO.	QTY.	PART NUMBER	DESCRIPTION
1	1	50120	Bracket, Wood to Wood
2	3	80020	Screw, FHP #10 X 1.25", Silver

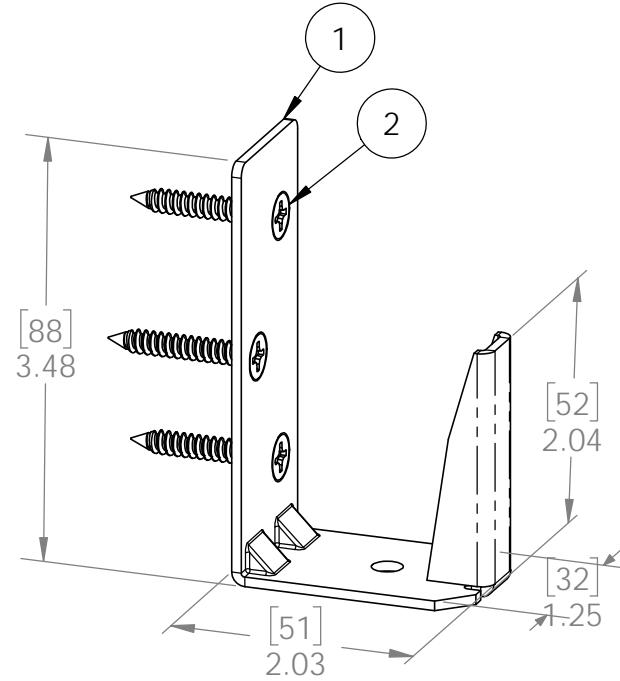
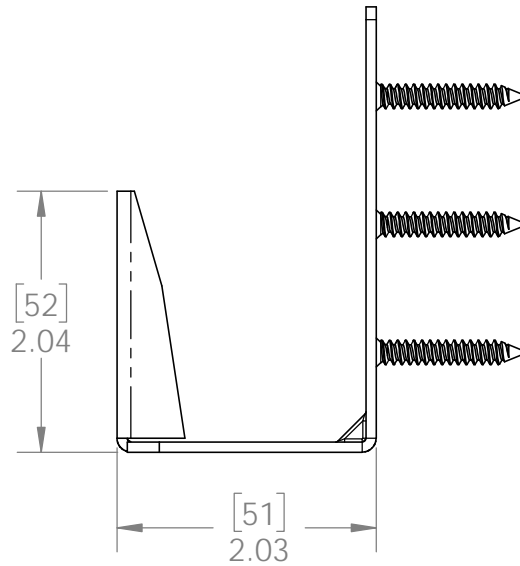
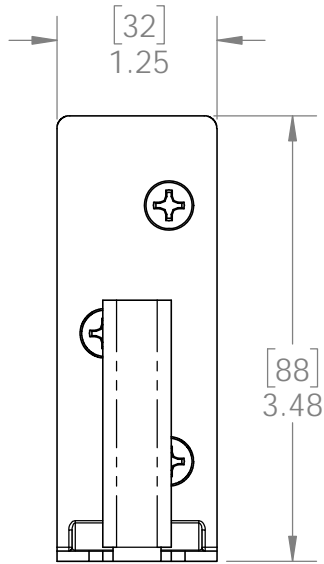

Weight: 0.21 LBS
 Scale: 1:1.5
 Last updated: 10/14/2016

50120





Product & Packaging Specs

Wood to Wood Bracket

Item #: Typical Installation & Basic Assembly

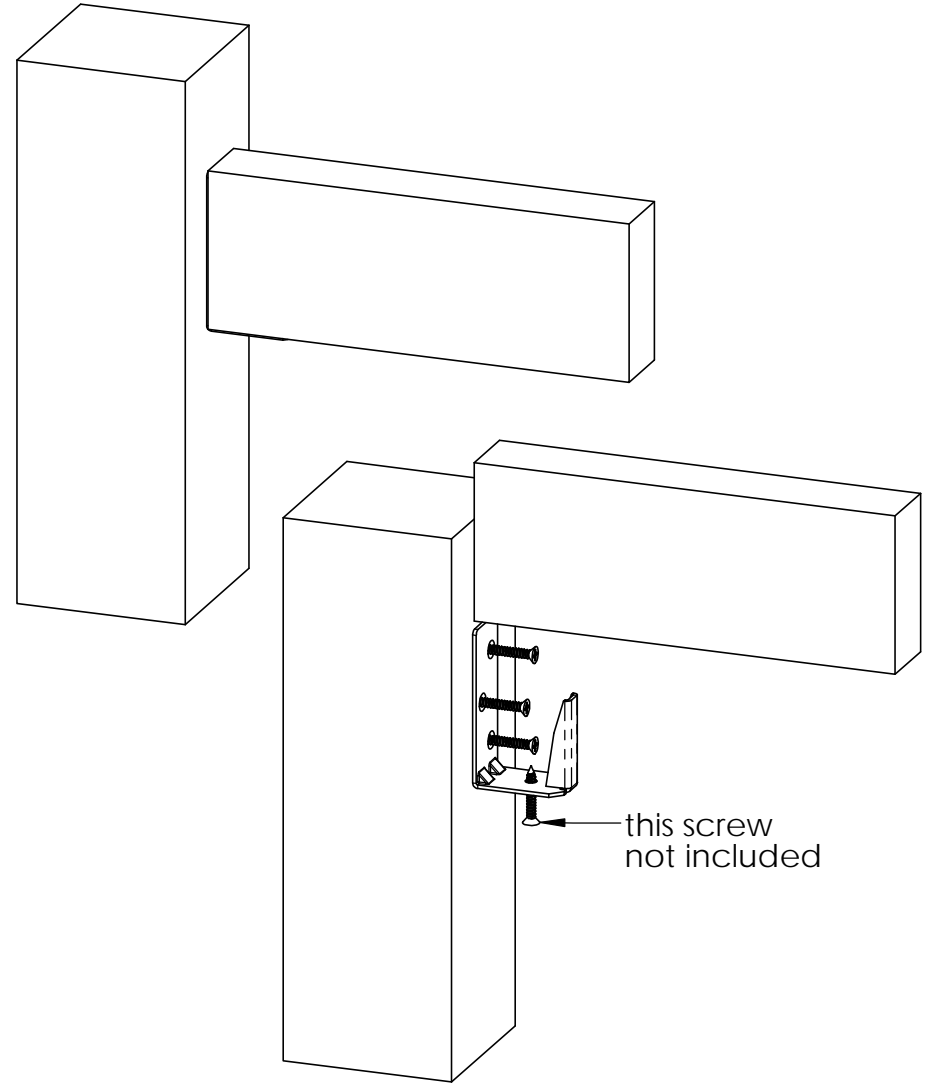
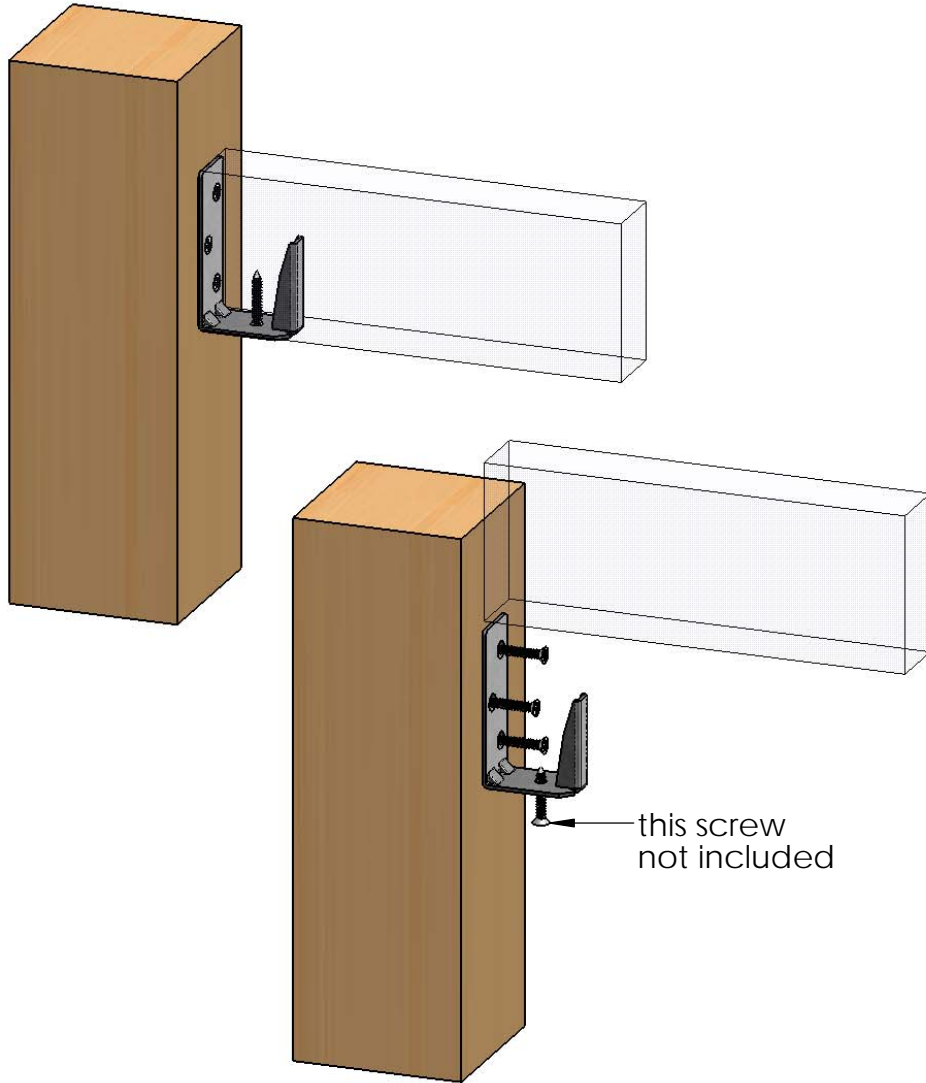

Scale: 1:4
Last updated: 10/14/2016

50120





Product & Packaging Specs

Wood to Wood Bracket (W2W-FB)

Item #: 50120

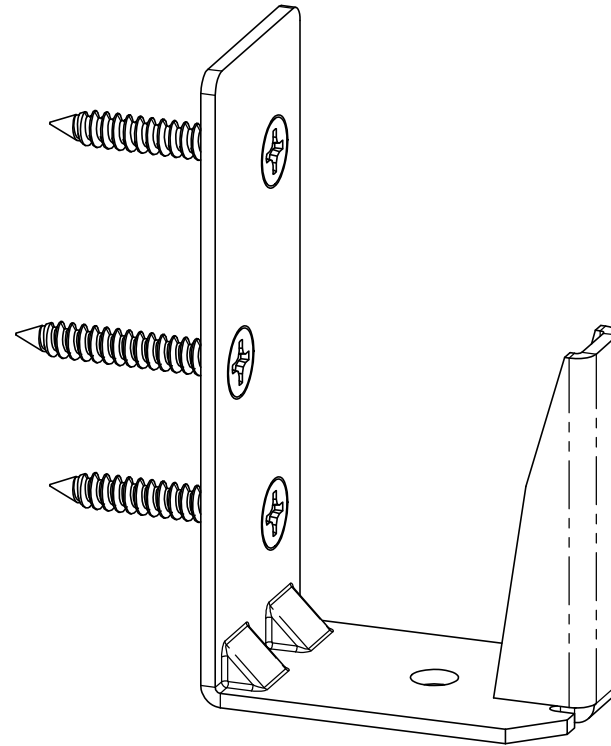
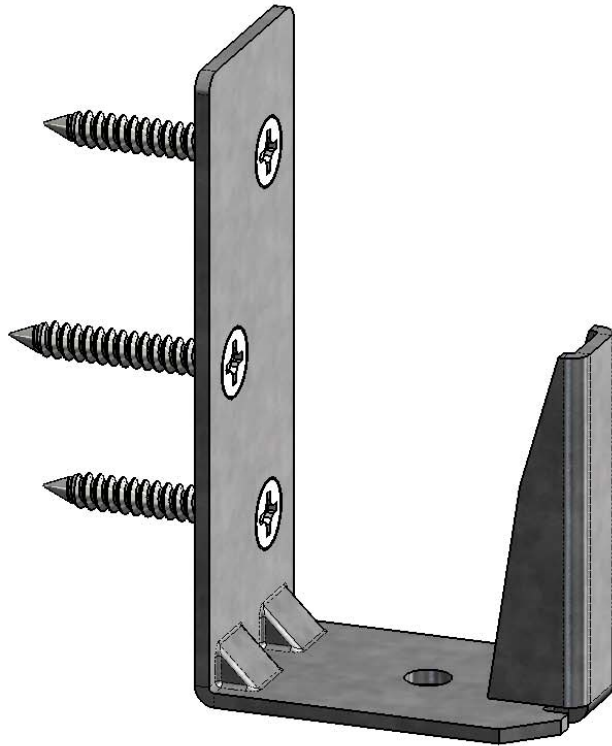

Weight: 0.21 LBS
Scale: 1:1
Last updated: 10/14/2016

50120



V2.00 - Installation Instructions, Specifications and Project Plans are effective 10/14/2016 . This information is updated periodically and should not be relied upon after 2 years from 10/14/2016 . Please visit OZCOBP.com to get current information. 3



Product & Packaging Specs

Wood to Wood Bracket (W2W-FB)

Item #: 50120

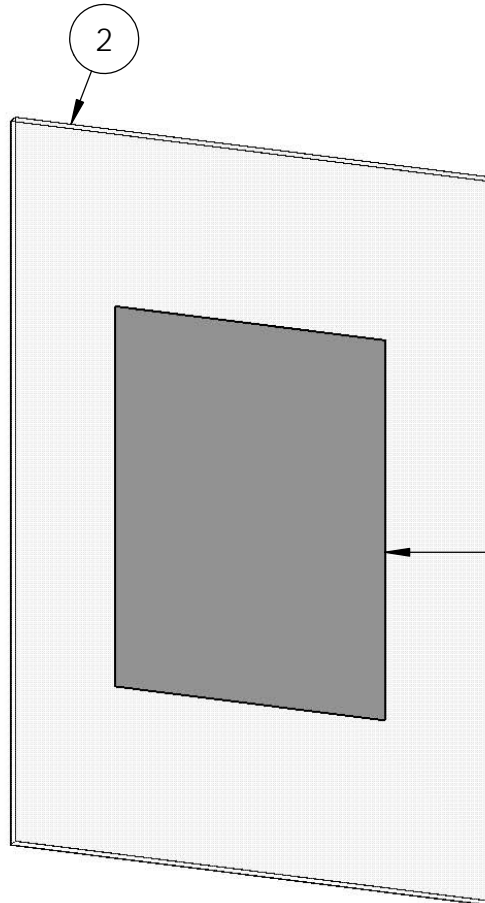
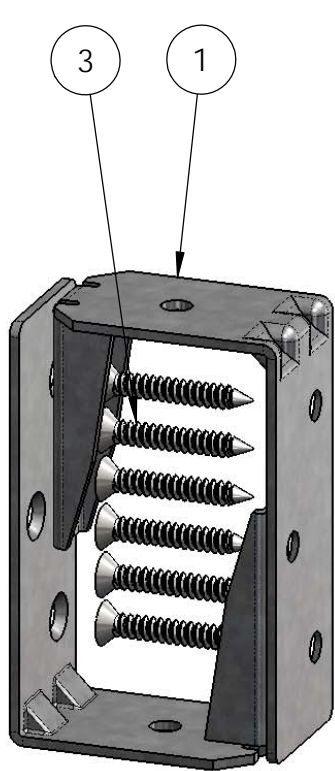

label, 2x3

ITEM NO.	QTY.	PART NUMBER	DESCRIPTION
1	2	50120	Bracket, Wood to Wood
2	6	80020	Screw, FHP #10 X 1.25", Silver
3	1	Bag, 3x4 packing	

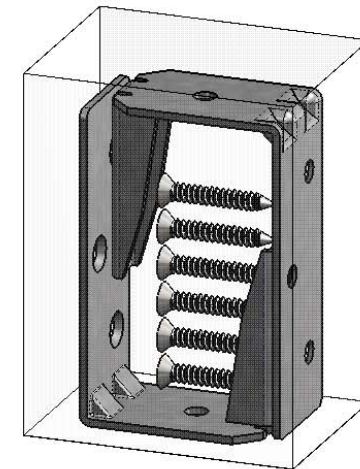

packed

Weight: 0.21 LBS
 Scale: 1:2
 Last updated: 10/14/2016

50120



V2.00 - Installation Instructions, Specifications and Project Plans are effective 10/14/2016 . This information is updated periodically and should not be relied upon after 2 years from 10/14/2016 . Please visit OZCOBP.com to get current information.



Product & Packaging Specs

Case, 50120 Packing

Item #: Case, 50120 Packing

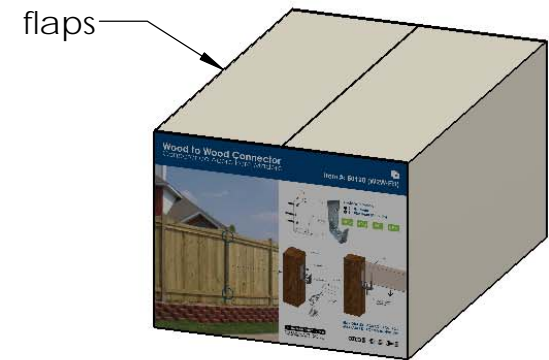
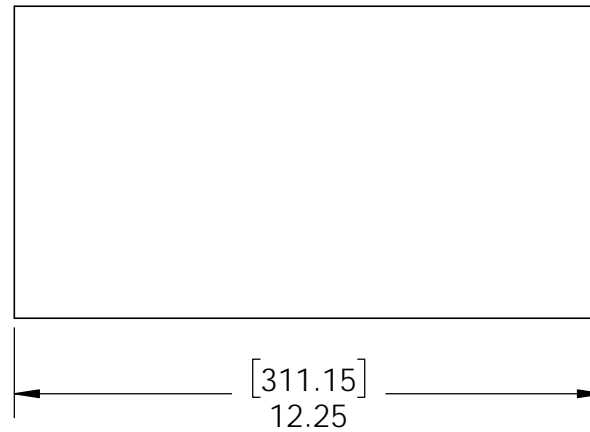
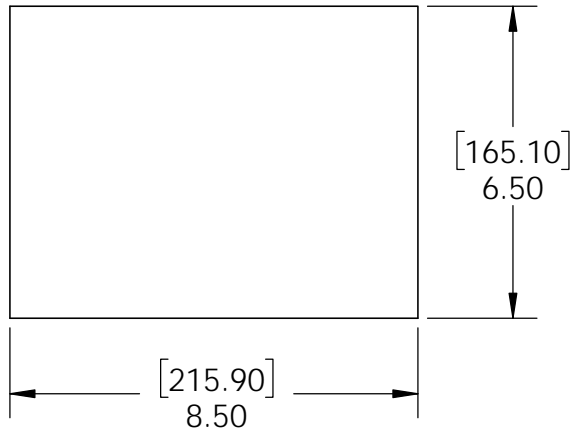

Material: Corrugated Paper
Finish: See artwork
Weight: 0.11 LBS
Scale: 1:4
Last updated: 10/14/2016

50120





Product & Packaging Specs

50120 Packing

Item #: Box packing



Weight: 21.36 LBS

Scale: 1:3

Last updated: 10/14/2016

50120



V2.00 - Installation Instructions, Specifications and Project Plans are effective 10/14/2016 . This information is updated periodically and should not be relied upon after 2 years from 10/14/2016 . Please visit OZCOBP.com to get current information.



Product & Packaging Specs

50120 Packing

Item #: Pallet packing

Item #: **50120** | **W2W-FB**

Wood 2 Wood Fence Bracket

PALLET **2000 pcs**

SKU#: **50122**



Weight: **1041** lbs

LOT# _____ Priority# _____

Total number of cases: 72

Total number of pieces:
72x50=3600 pieces on pallet

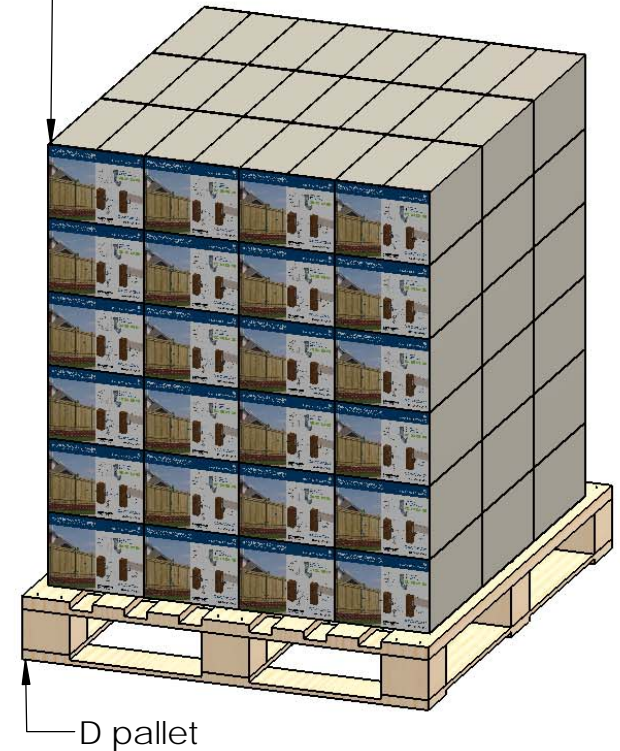
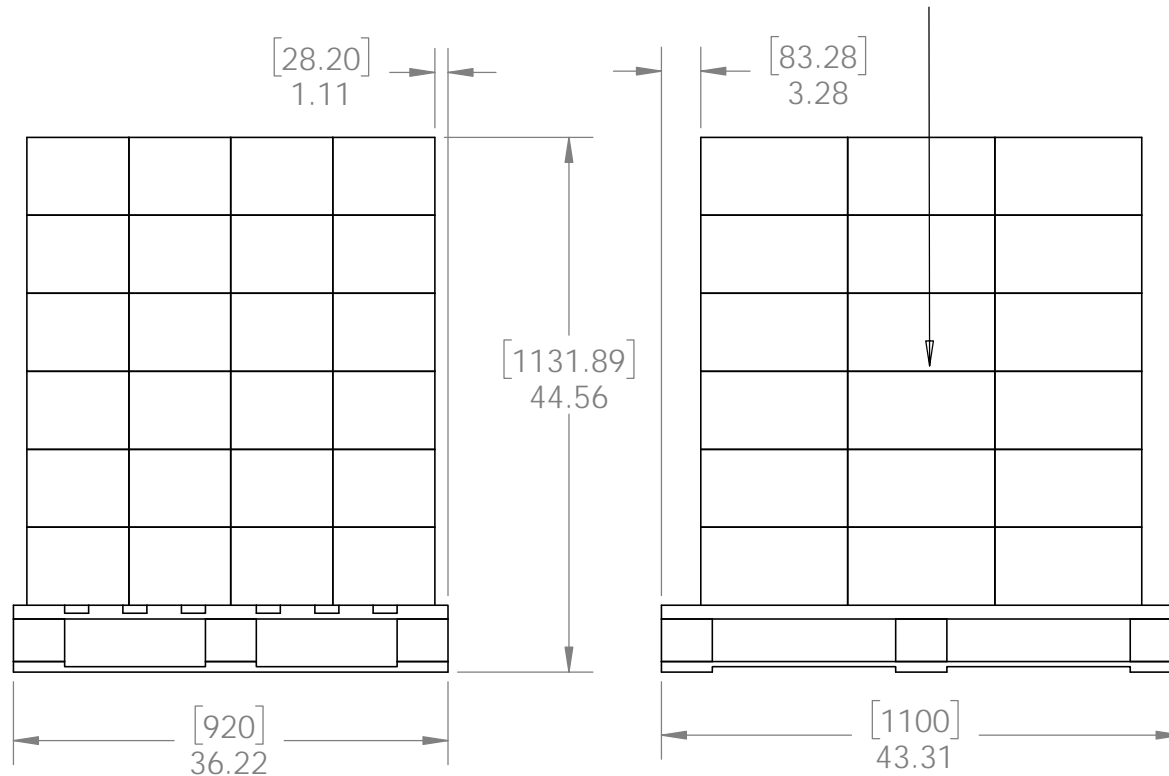

Weight: 1041 LBS
Scale: 1:2
Last updated: 10/14/2016

additional pallet packing instructions
plywood on top layer
strap to pallet
clear wrap around boxes



50120