



Product & Packaging Specs

2 3/8" Steel to Wood Bracket

Item #: 50100

ITEM NO.	QTY.	PART NUMBER	DESCRIPTION
1	1	50100-12	Bracket, 2-3/8" Steel to Wood Tube
2	1	50100-11	Bracket, 2-3/8" Steel to Wood Chassis
3	4	80055	Screw, Lag, 1/4" x 1-1/4"
4	2	80125	Nut, Hex 5/16-18
5	2	80112	Bolt, Carriage 5/16-18 x 1.5

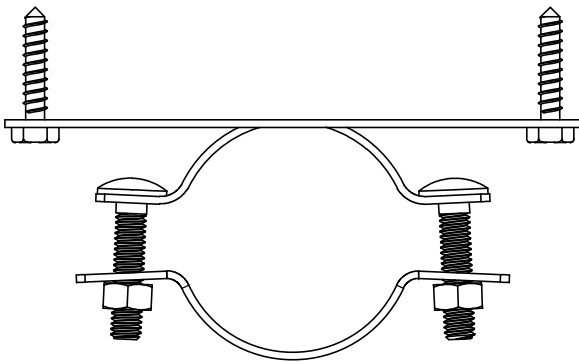

shown assembled

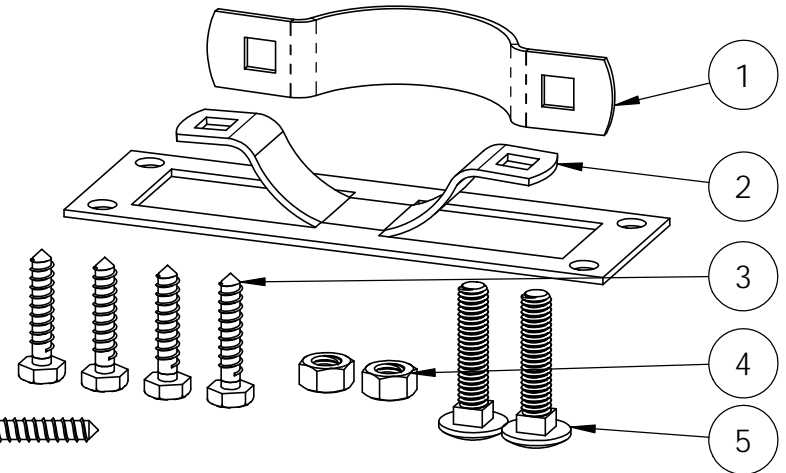
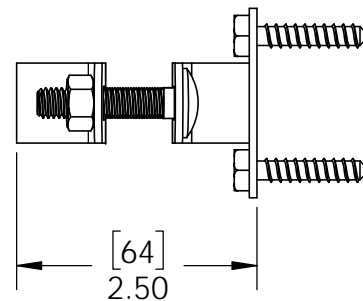
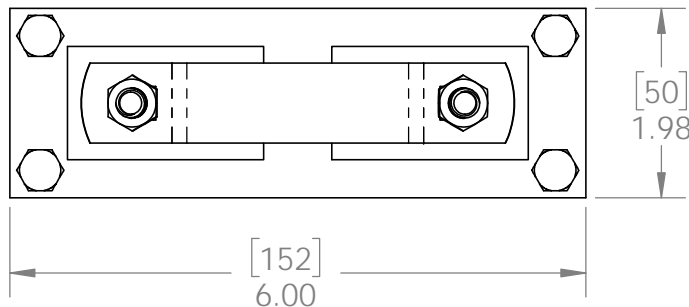

#50100 Individual Sale
#50130 50 Pro Pack



Weight: 0.50 LBS
Scale: 1:2
Last updated: 4/28/2016

50100-10



Product & Packaging Specs

2 3/8" Steel to Wood Bracket

Item #: 50100

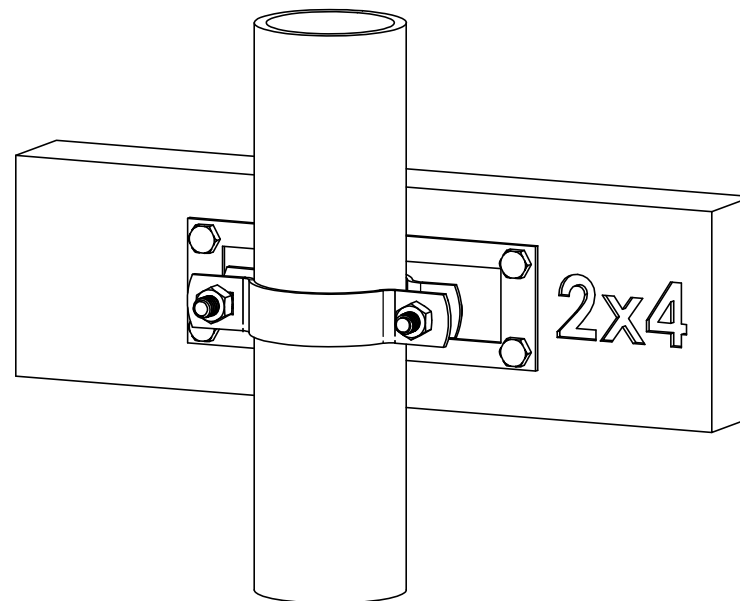
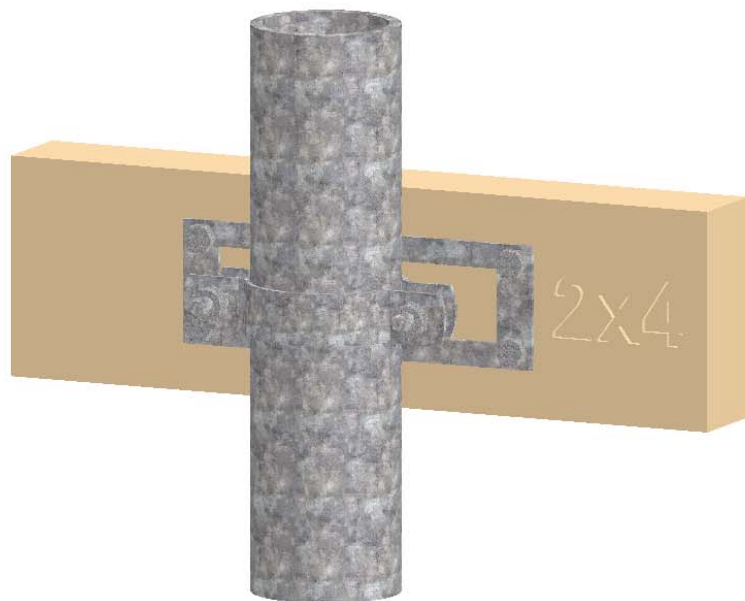

Weight: 0.50 LBS
Scale: 1:3
Last updated: 4/28/2016

50100-10



V2.00 - Installation Instructions, Specifications and Project Plans are effective 4/28/2016. This information is updated periodically and should not be relied upon after 2 years from 4/28/2016. Please visit OZCOBP.com to get current information.



Product & Packaging Specs

2 3/8" Steel to Wood Bracket

Item #: 50100

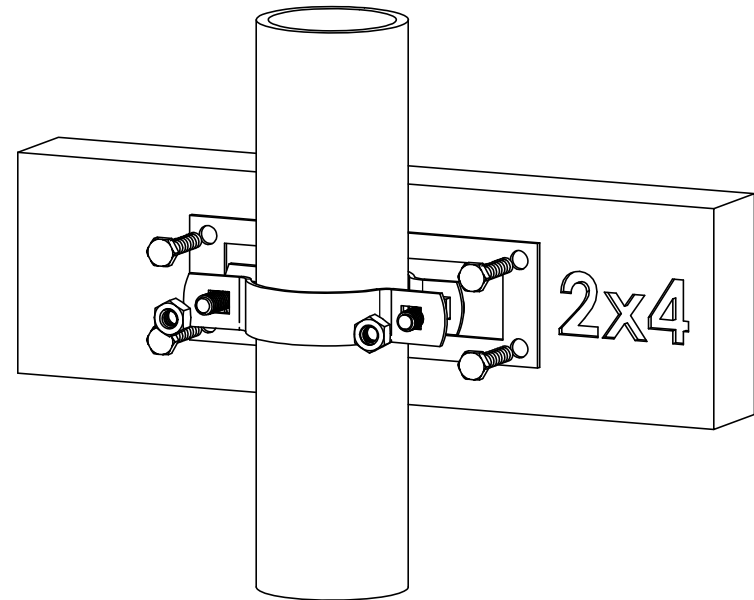
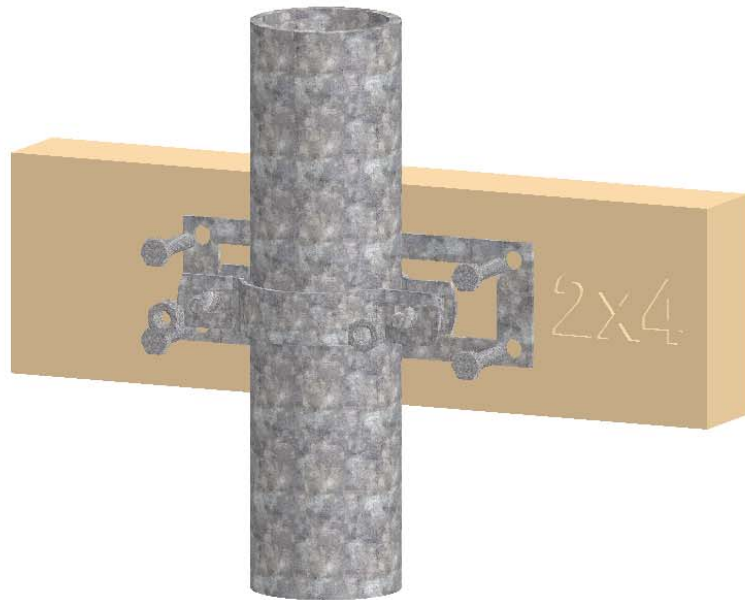

Weight: 0.50 LBS
Scale: 1:3
Last updated: 4/28/2016

50100-10



V2.00 - Installation Instructions, Specifications and Project Plans are effective 4/28/2016 . This information is updated periodically and should not be relied upon after 2 years from 4/28/2016 . Please visit OZCOBP.com to get current information.