

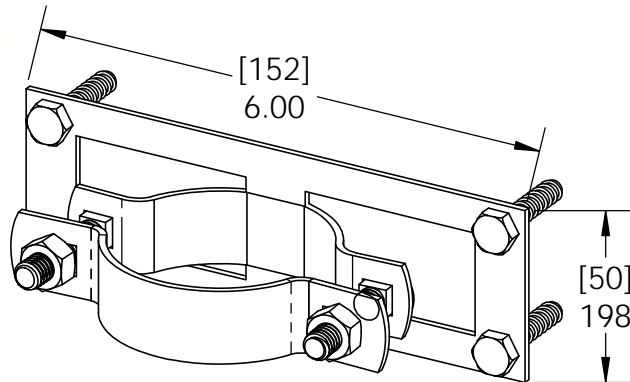

Product & Packaging Specs

2-3/8" Steel to Wood Bkt (WAP-238)

Item #: 50100



ITEM NO.	QTY.	PART NUMBER	DESCRIPTION
1	1	50100-12	Bracket, 2-3/8" Steel to Wood Tube
2	1	50100-11	Bracket, 2-3/8" Steel to Wood Chassis
3	4	80055	Screw, Lag, 1/4" x 1-1/4"
4	2	80125	Nut, Hex 5/16-18
5	2	80112	Bolt, Carriage 5/16-18 x 1.5

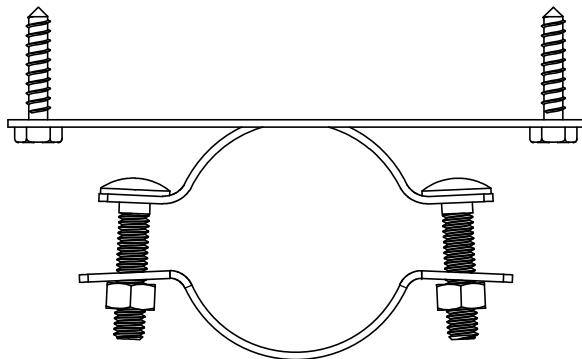

shown assembled

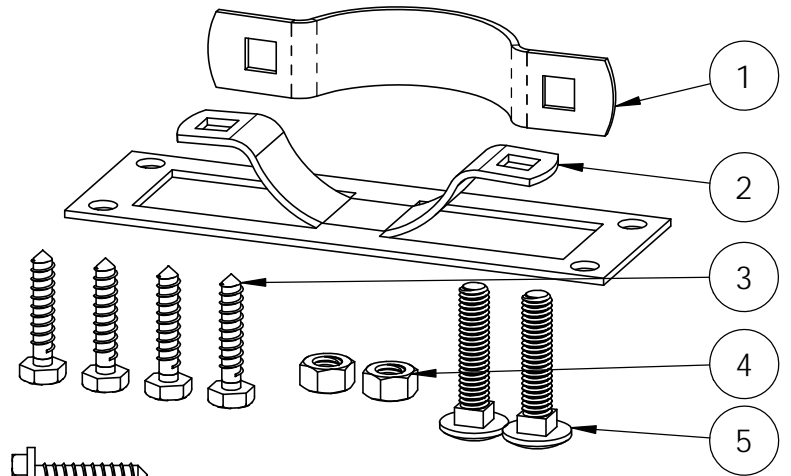
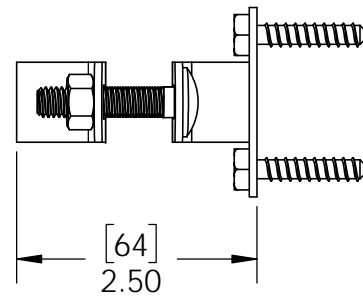
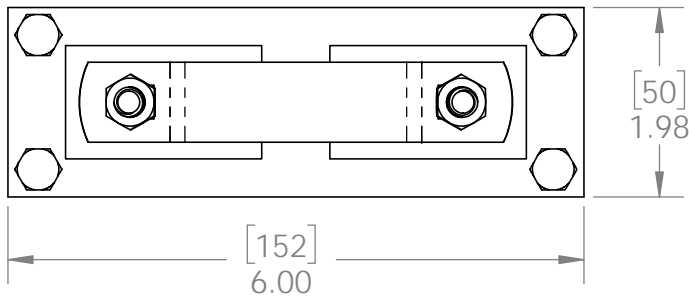

#50100 Individual Sale
#50130 50 Pro Pack

Weight: 0.50 LBS
Scale: 1:2
Last updated: 10/14/2016

50100-10



V2.00 - Installation Instructions, Specifications and Project Plans are effective 10/14/2016. This information is updated periodically and should not be relied upon after 2 years from 10/14/2016. Please visit OZCOBP.com to get current information.



Product & Packaging Specs

2-3/8" Steel to Wood Bkt (WAP-238)

Item #: 50100

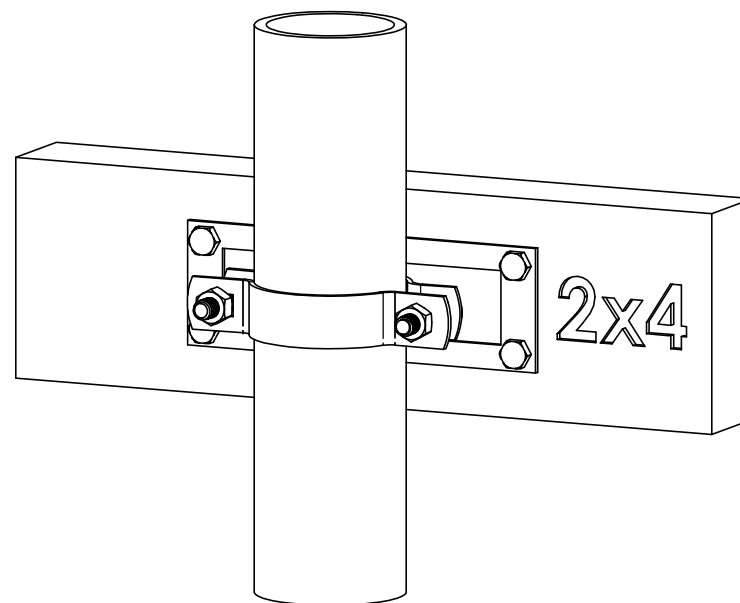
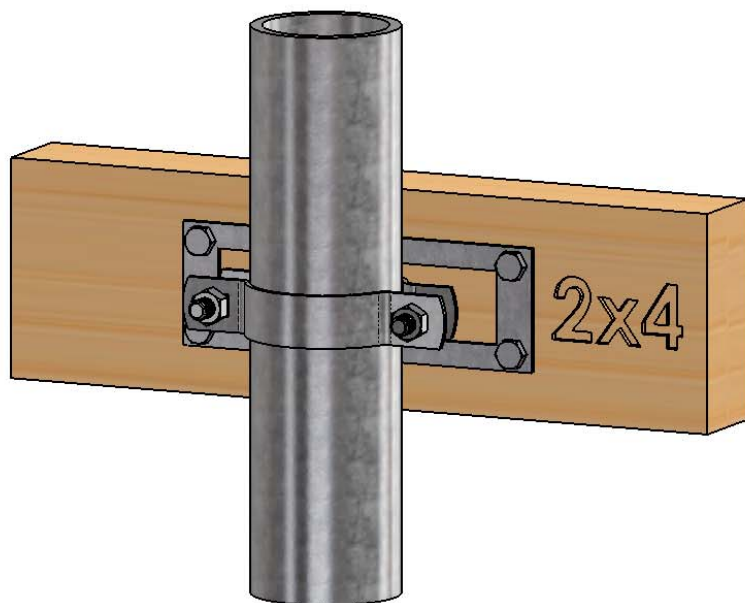

Weight: 0.50 LBS
Scale: 1:3
Last updated: 10/14/2016

50100-10



V2.00 - Installation Instructions, Specifications and Project Plans are effective 10/14/2016 . This information is updated periodically and should not be relied upon after 2 years from 10/14/2016 . Please visit OZCOBP.com to get current information. 2



Product & Packaging Specs

2-3/8" Steel to Wood Bkt (WAP-238)

Item #: 50100

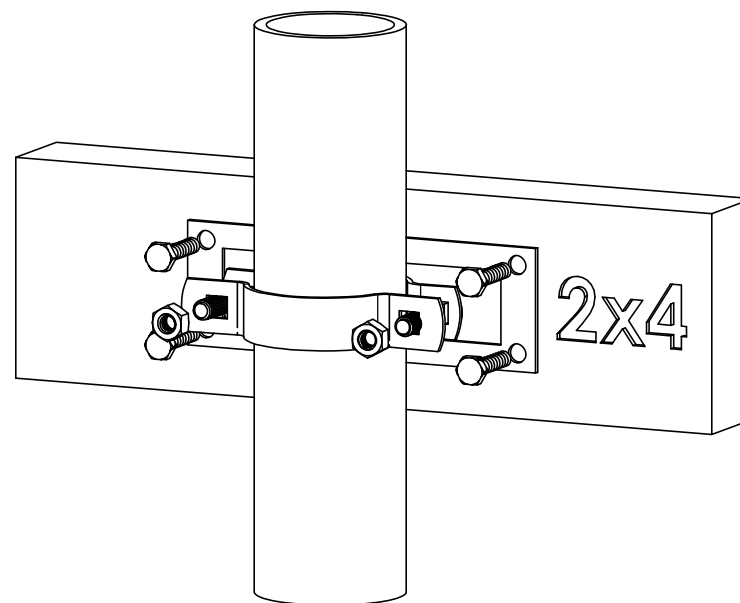
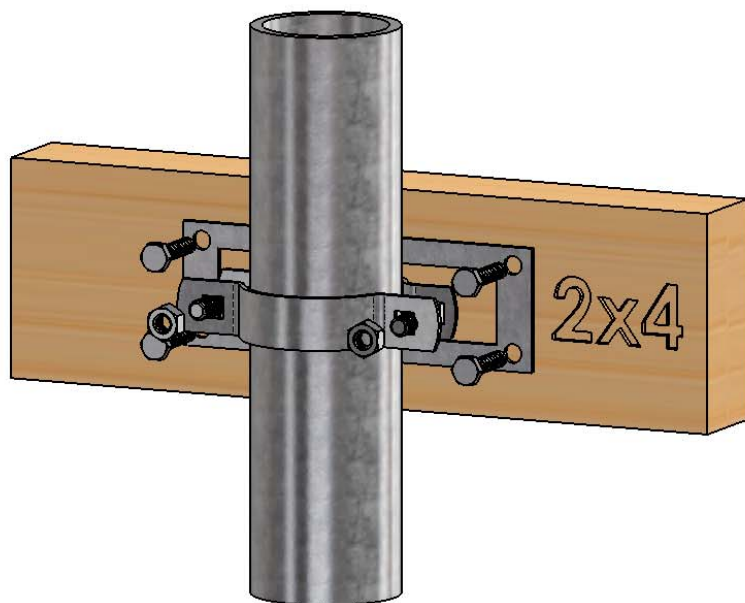

Weight: 0.50 LBS
Scale: 1:3
Last updated: 10/14/2016

50100-10



V2.00 - Installation Instructions, Specifications and Project Plans are effective 10/14/2016 . This information is updated periodically and should not be relied upon after 2 years from 10/14/2016 . Please visit OZCOBP.com to get current information.



Product & Packaging Specs

Case, 50130

Item #: Case

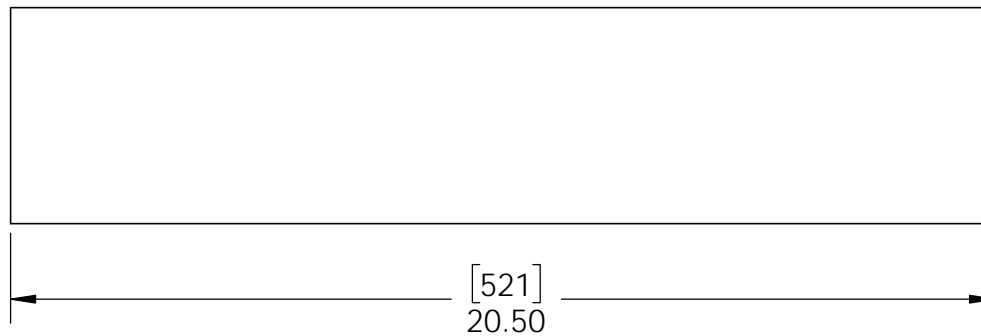
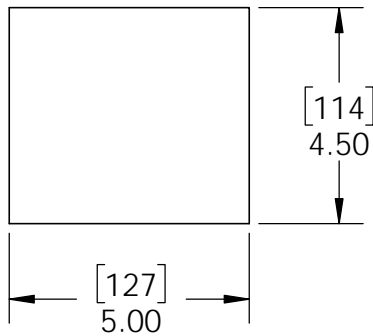

Material: Corrugated Paper
Finish: see artwork
Weight: 0.19 LBS
Scale: 1:4
Last updated: 10/14/2016

50100-10



V2.00 - Installation Instructions, Specifications and Project Plans are effective 10/14/2016 . This information is updated periodically and should not be relied upon after 2 years from 10/14/2016 . Please visit OZCOBP.com to get current information.



Product & Packaging Specs

Box, 50130 Fasteners

Item #: Box

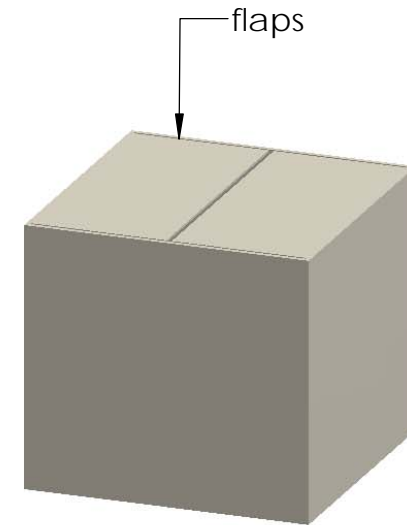
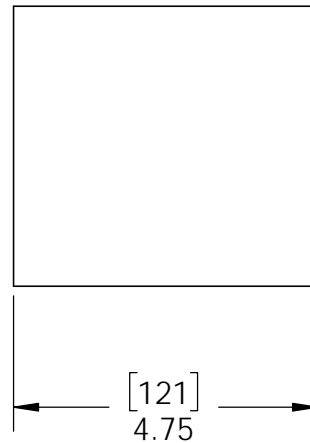
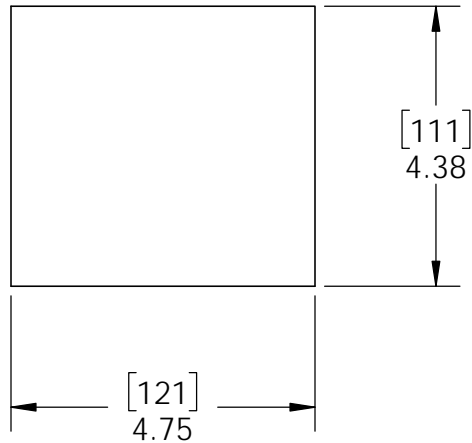

Material: Corrugated Paper
Finish: None
Weight: 0.05 LBS
Scale: 1:3
Last updated: 10/14/2016

50100-10



V2.00 - Installation Instructions, Specifications and Project Plans are effective 10/14/2016 . This information is updated periodically and should not be relied upon after 2 years from 10/14/2016 . Please visit OZCOBP.com to get current information.



Product & Packaging Specs

50130 Packing

Item #: Case packing

boxes shown
without flaps for
clarity

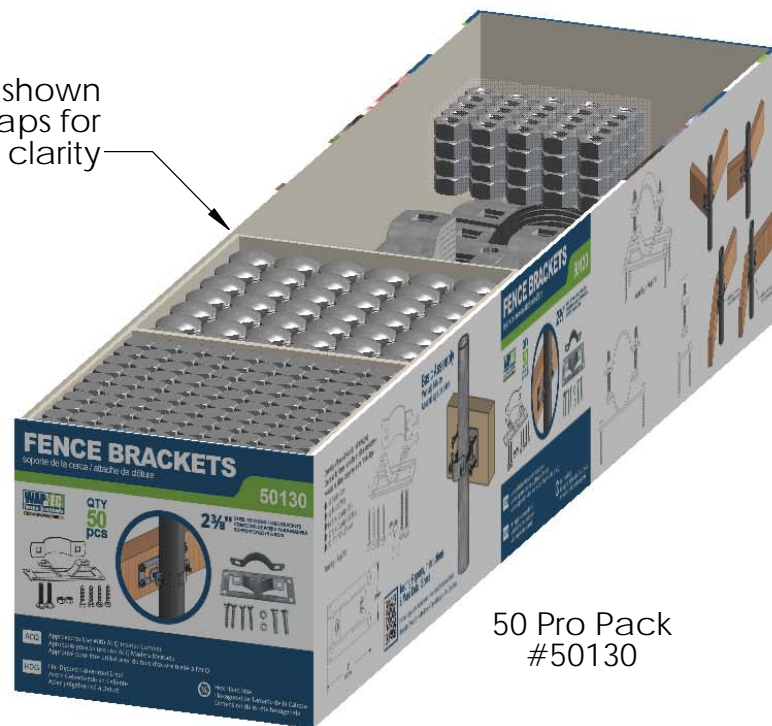

50 Pro Pack
#50130

ITEM NO.	QTY.	PART NUMBER	DESCRIPTION
1	1	Case, 50130	Case, 50130
2	50	50100-11	Bracket, 2-3/8" Steel to Wood Chassis
3	50	50100-12	Bracket, 2-3/8" Steel to Wood Tube
4	100	80112	Bolt, Carriage 5/16-18 x 1.5
5	100	80125	Nut, Hex 5/16-18
6	200	80055	Screw, Lag, 1/4" x 1-1/4"
7	1	Bag, 2x3 packing	Bag, 2x3 Packing
8	2	Box, 50130 Fasteners	Box, 50130 Fasteners

Weight: 25.28 LBS

Scale: 1:3

Last updated: 10/14/2016

50100-10



V2.00 - Installation Instructions, Specifications and Project Plans are effective 10/14/2016 . This information is updated periodically and should not be relied upon after 2 years from 10/14/2016 . Please visit OZCOBP.com to get current information.



Product & Packaging Specs

50130 Side Stack

Item #: 50130 Side Stack

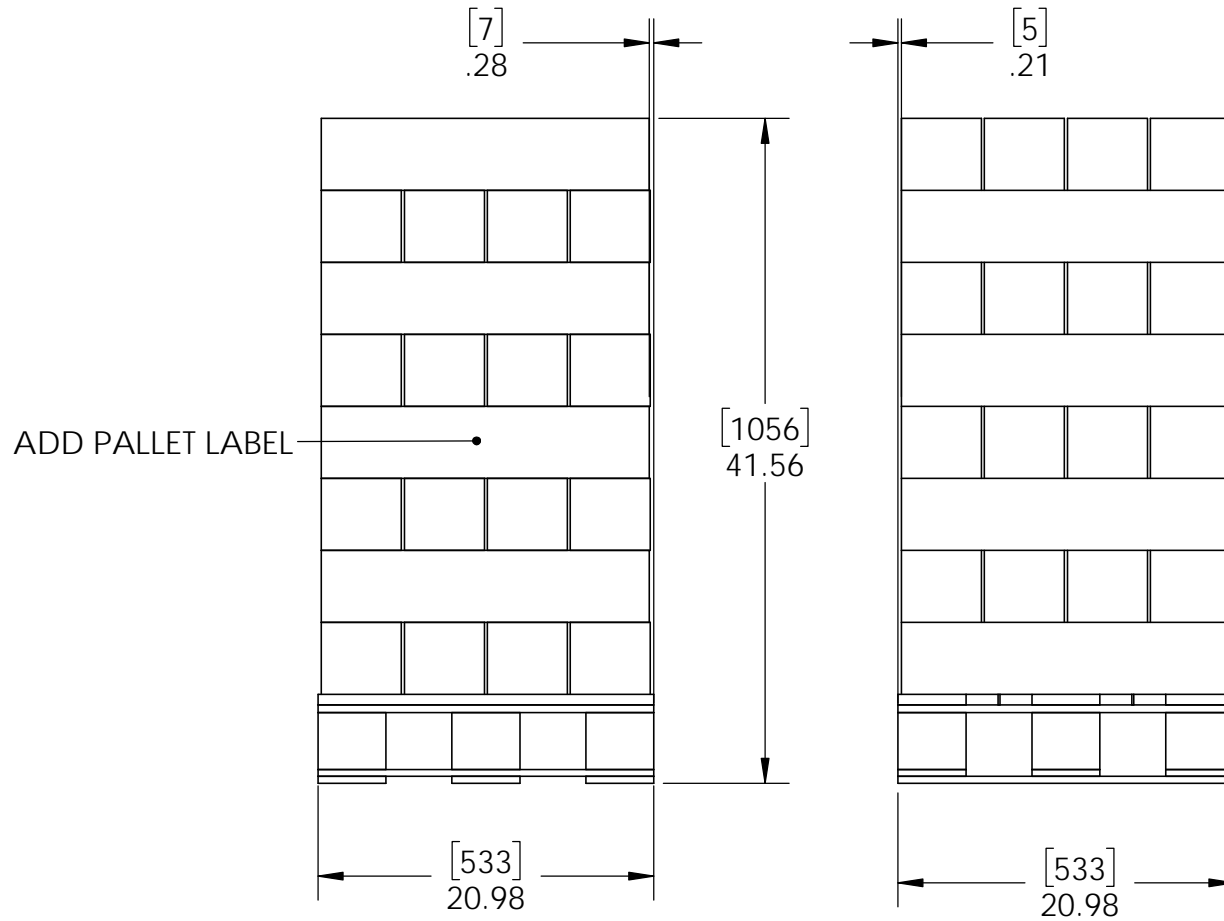

Total number of cases: 32
32x50=1600 pieces on pallet



Y pallet

additional pallet packing instructions
plywood on top layer
strap to pallet
clear wrap around boxes

Weight: 850 LBS
Scale: 1:12
Last updated: 10/14/2016

50100-10





Product & Packaging Specs

50130 Container Packing

Item #: Quad Packing

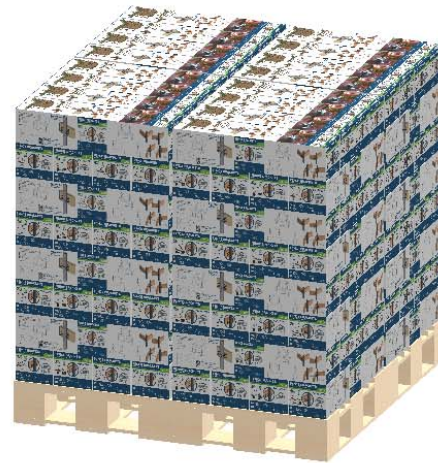

Side Stacks
plywood or
equivalent on top,
shrink wrap & band
together
6400 pieces

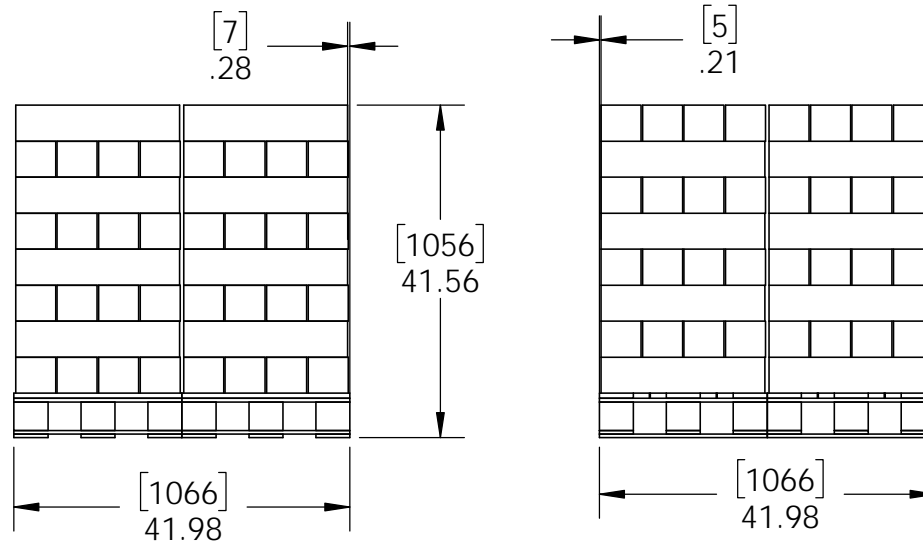

Weight: 3400 LBS
Scale: 1:24
Last updated: 10/14/2016

50100-10



V2.00 - Installation Instructions, Specifications and Project Plans are effective 10/14/2016 . This information is updated periodically and should not be relied upon after 2 years from 10/14/2016 . Please visit OZCOBP.com to get current information.



Product & Packaging Specs

50130 Container Packing

Item #: Container Packing

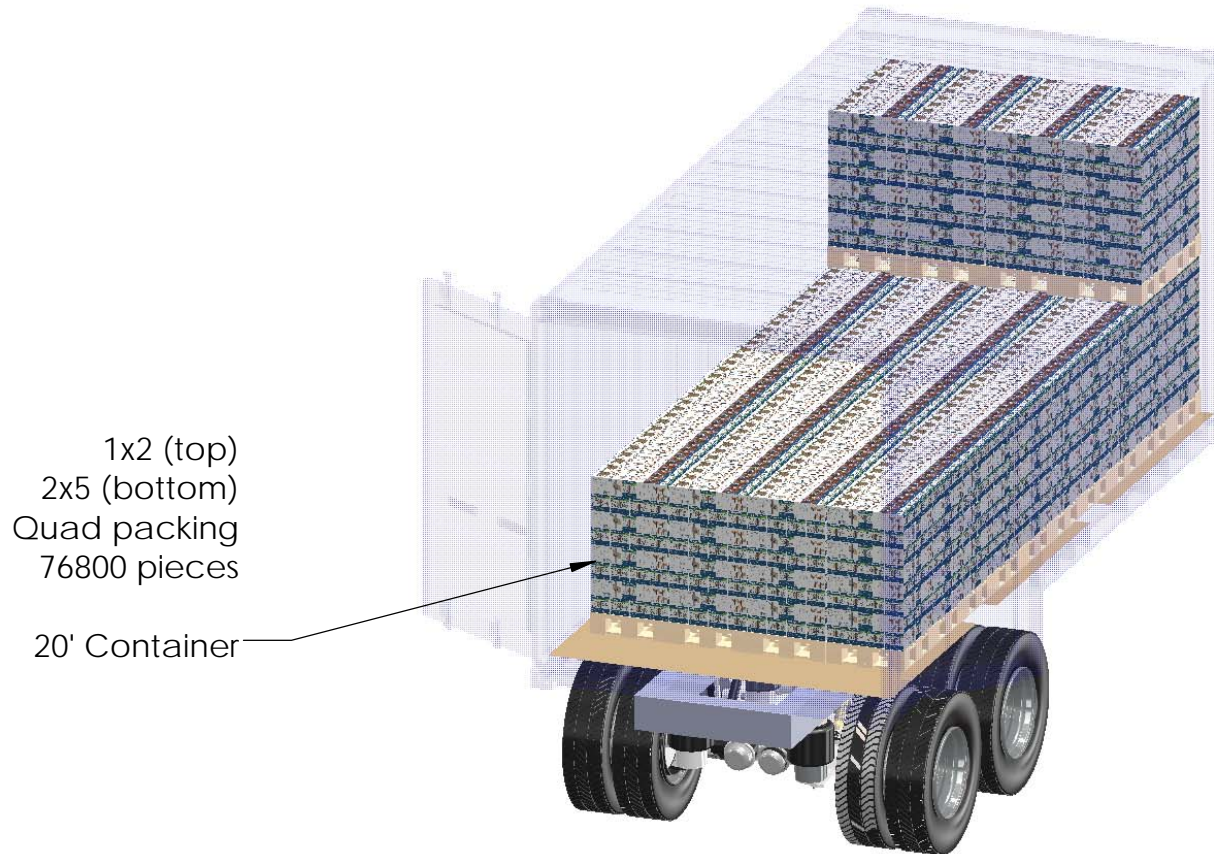

1x2 (top)
2x5 (bottom)
Quad packing
76800 pieces
20' Container

Weight: 40800 LBS
Scale: 1:48
Last updated: 10/14/2016

50100-10



V2.00 - Installation Instructions, Specifications and Project Plans are effective 10/14/2016 . This information is updated periodically and should not be relied upon after 2 years from 10/14/2016 . Please visit OZCOBP.com to get current information.