



OZCO BUILDING PRODUCTS

Product & Packaging Specs

OWT Hardware Accessory - Wine Glass Holder (HA-WGH)
Item #: 57703

| ITEM NO. | QTY. | PART NUMBER | DESCRIPTION |
|----------|------|-------------|--|
| 1 | 1 | 57703 | OWT Hardware Accessory - Wine Glass Holder |
| 2 | 2 | Screw | Screw, .25-20 x .375 Torx Black with Locking Patch |

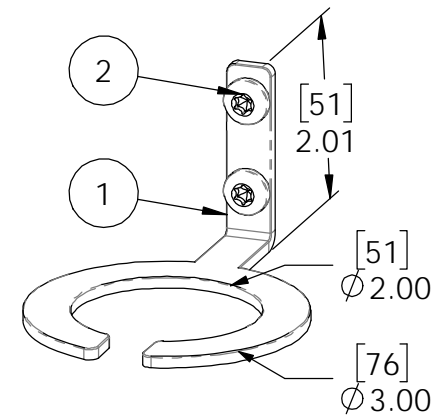
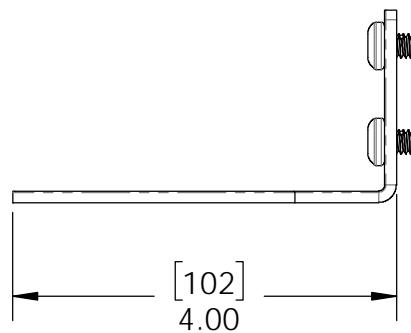
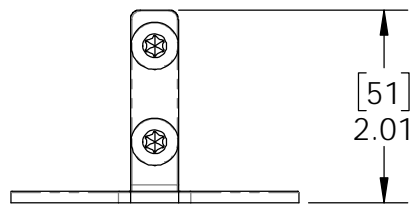
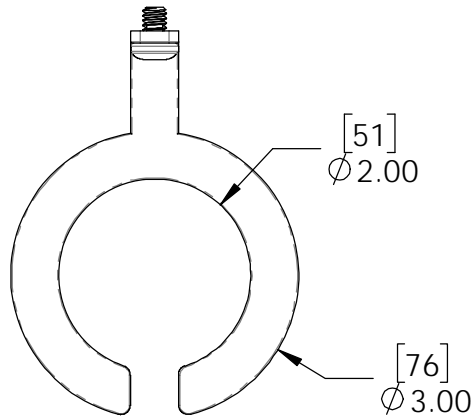

Weight: 0.20 LBS
Scale: 1:2
Last updated: 12/21/2017

57703

V2.00 - Installation Instructions, Specifications and Project Plans are effective 12/21/2017 . This information is updated periodically and should not be relied upon after 2 years from 12/21/2017 . Please visit OZCOBP.com to get current information.



Product & Packaging Specs

OWT Hardware Accessory - Wine Glass Holder (HA-WGH)
Item #: 57703

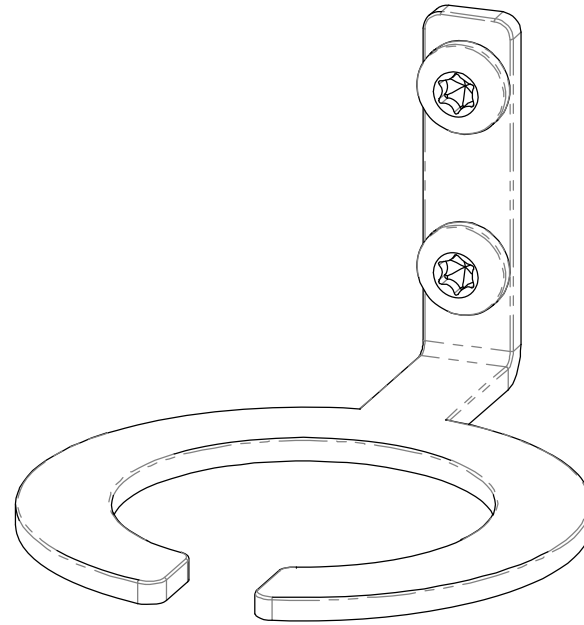

Weight: 0.20 LBS
Scale: 1:1
Last updated: 12/21/2017

57703

V2.00 - Installation Instructions, Specifications and Project Plans are effective 12/21/2017 . This information is updated periodically² and should not be relied upon after 2 years from 12/21/2017 . Please visit OZCOBP.com to get current information.



OZCO BUILDING PRODUCTS

Product & Packaging Specs

OWT Hardware Accessory - Wine Glass Holder (HA-WGH)
Item #: 57703

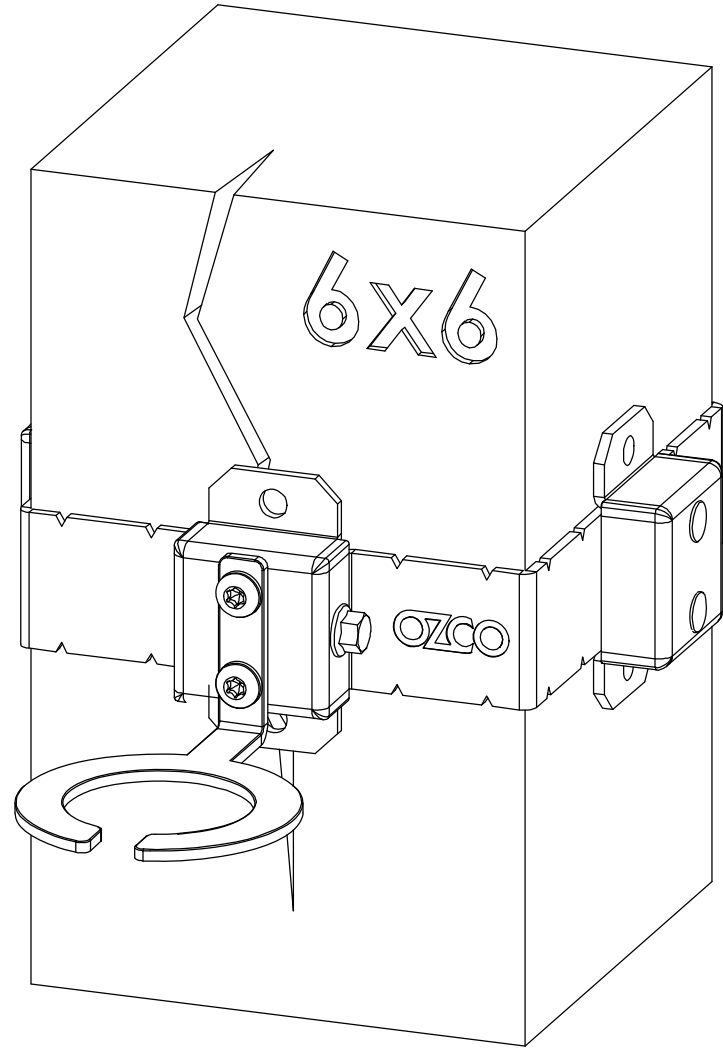
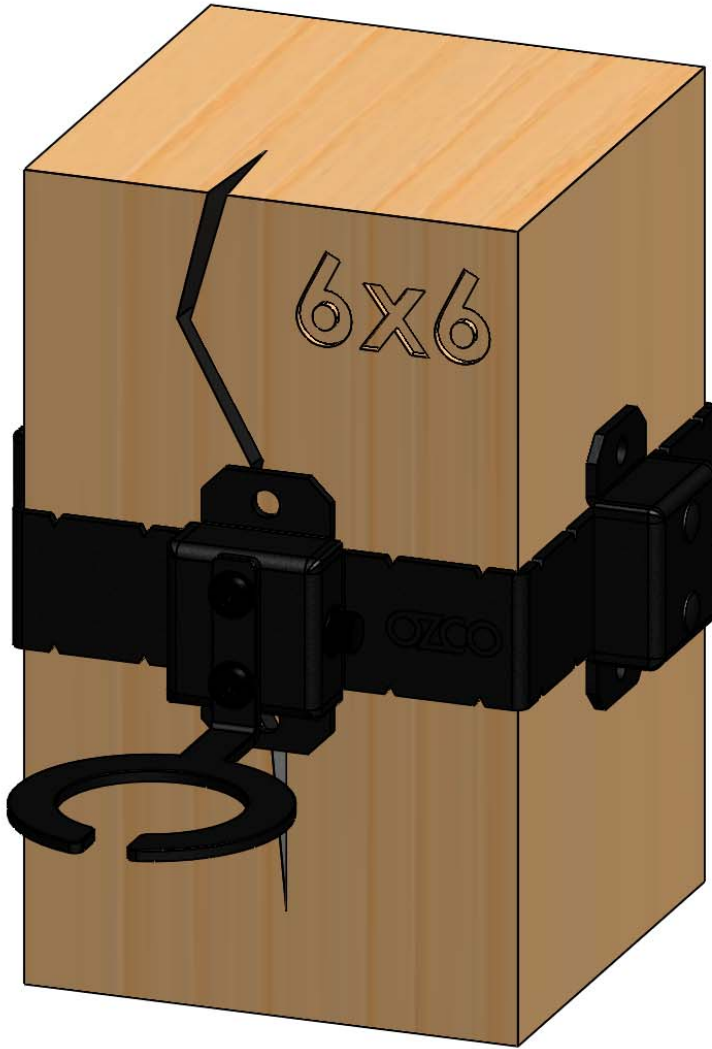

Weight: 0.20 LBS
Scale: 1:2
Last updated: 12/21/2017

57703

shown installed on 6x6 Post Band (51786); 4x4 & 8x8 Post Bands available

V2.00 - Installation Instructions, Specifications and Project Plans are effective 12/21/2017 . This information is updated periodically and should not be relied upon after 2 years from 12/21/2017 . Please visit OZCOBP.com to get current information.

Product & Packaging Specs

57703 Packing

Item #: Box packing



| ITEM NO. | Box packing/ QTY. | PART NUMBER | DESCRIPTION |
|----------|-------------------|-------------|--|
| 1 | 2 | Screw | Screw, .25-20 x .375 Torx Black with Locking Patch |
| 2 | 1 | 57703 | OWT Hardware Accessory - Wine Glass Holder |
| 3 | 1 | Box, 57703 | Box, 57703 |
| 4 | 1 | Box, 57703 | Box, 57703 |

Weight: .3 LBS
Scale: 1:2
Last updated: 12/21/2017

57703

Product & Packaging Specs

Case, 57703

Item #: Case

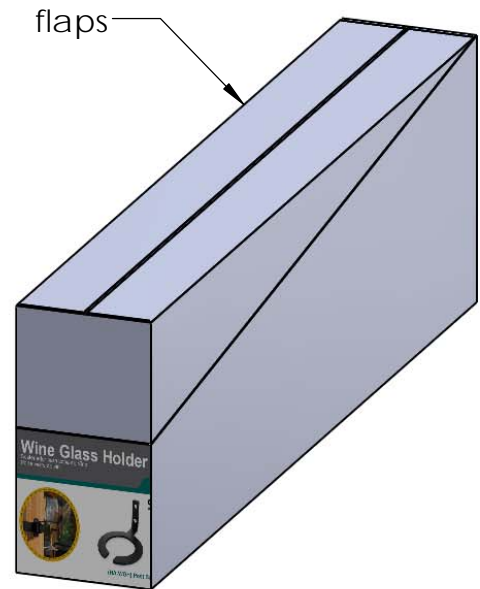
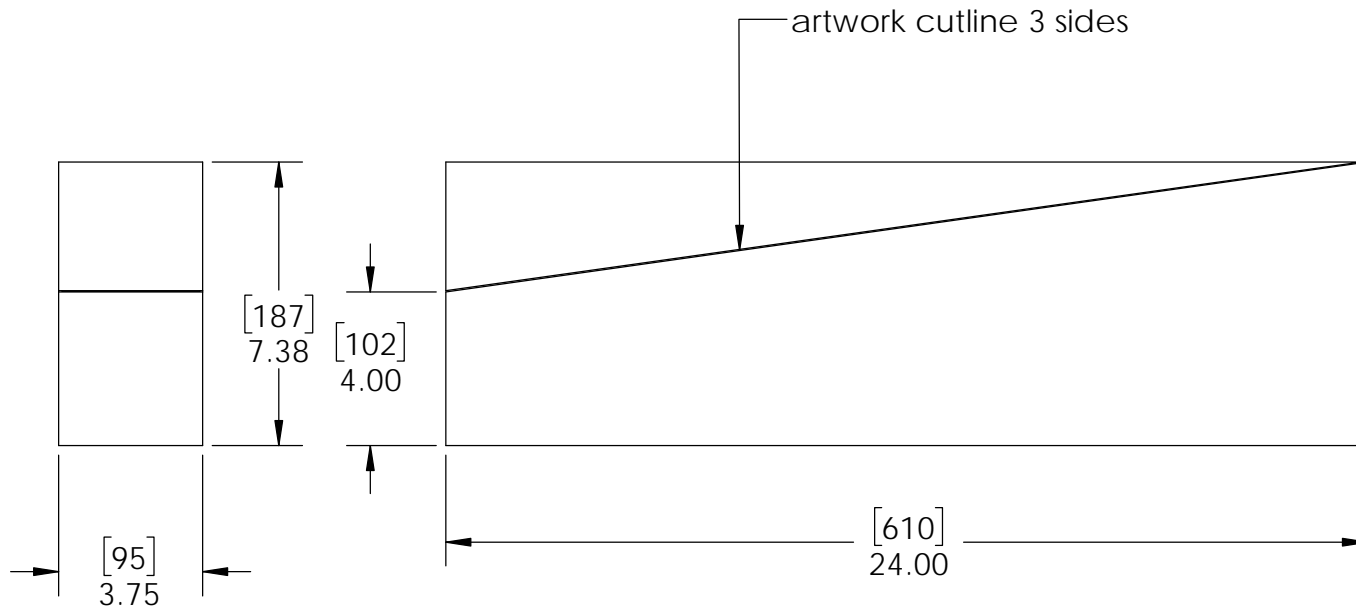

Material: Corrugated Paper
Finish: See Artwork
Weight: 0.26 LBS
Scale: 1:5
Last updated: 12/21/2017

57703

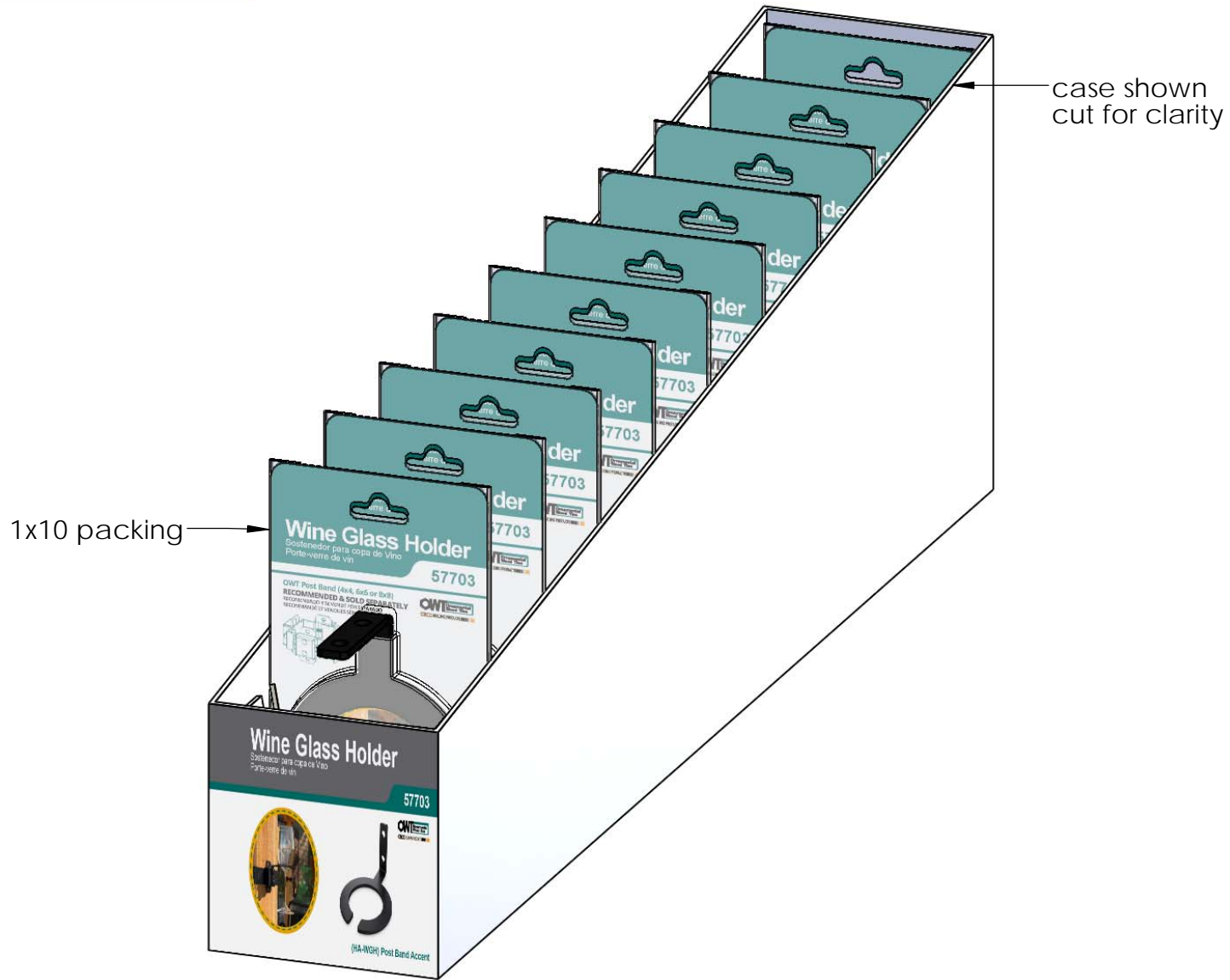

Weight: 3 LBS
Scale: 1:2.5
Last updated: 12/21/2017

57703

Product & Packaging Specs

57703 Packing

Item #: Pallet packing

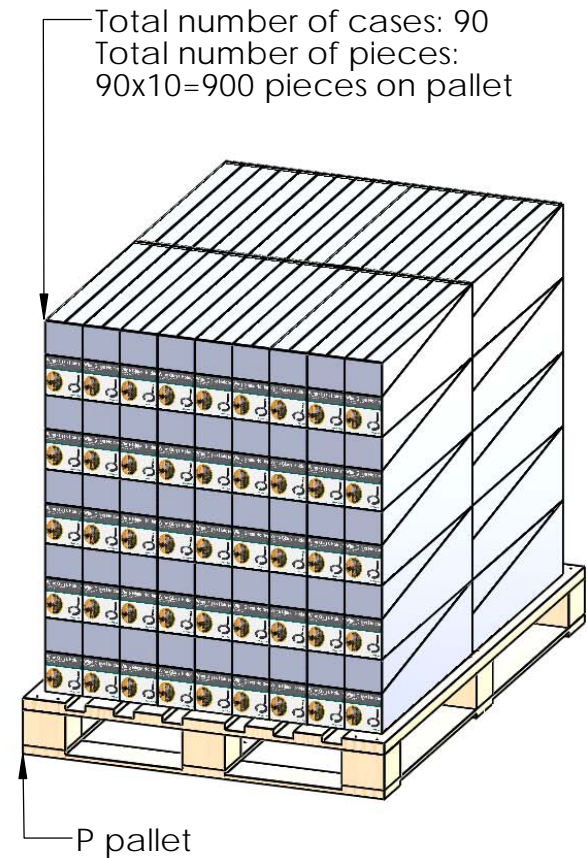
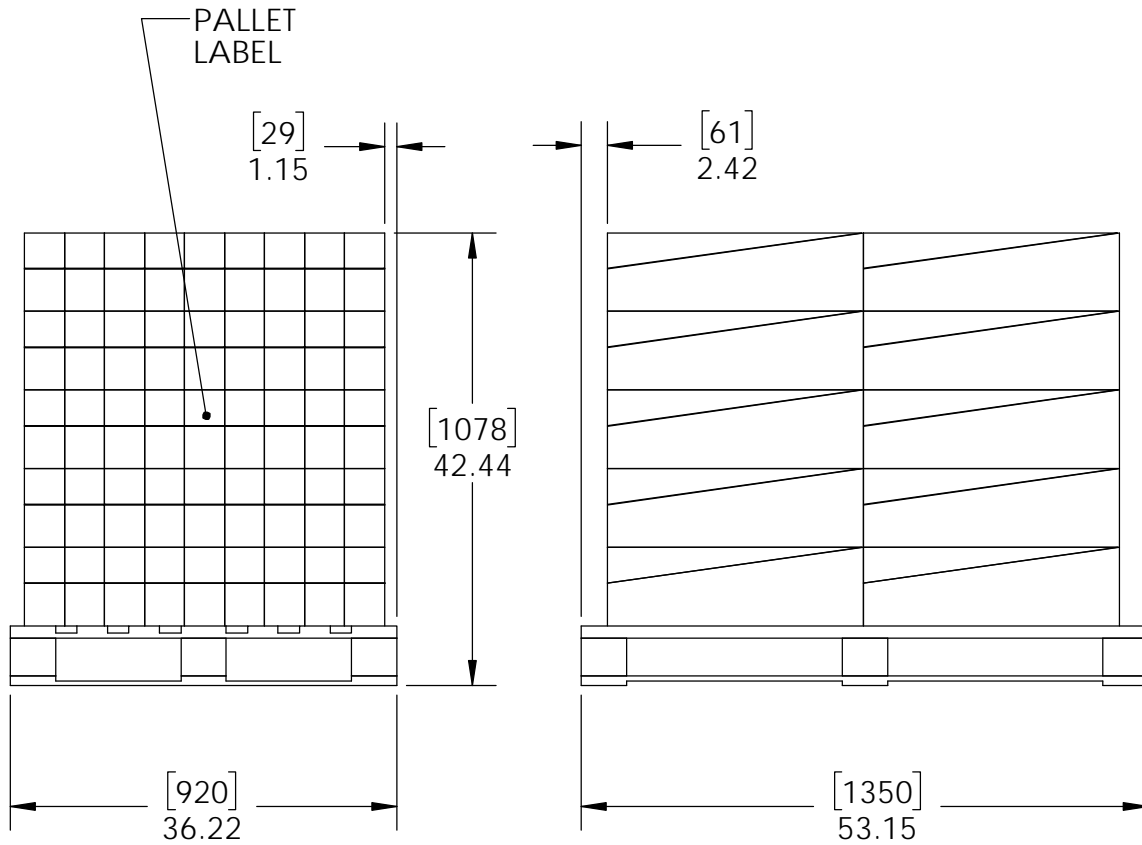

Weight: 300 LBS
 Scale: 1:18
 Last updated: 12/21/2017

57703

additional pallet packing instructions

- plywood on top layer
- strap to pallet
- clear wrap around boxes

