

Product & Packaging Specs

1-1/4" Hammered Dome Cap Nut

Item #: 56622

ITEM NO.	QTY.	PART NUMBER	DESCRIPTION
1	1	56622-12	Base, 1-1/4" Hammered Dome Cap Nut
2	1	56622-11	Nut, 1-1/4" Hammered Dome Cap

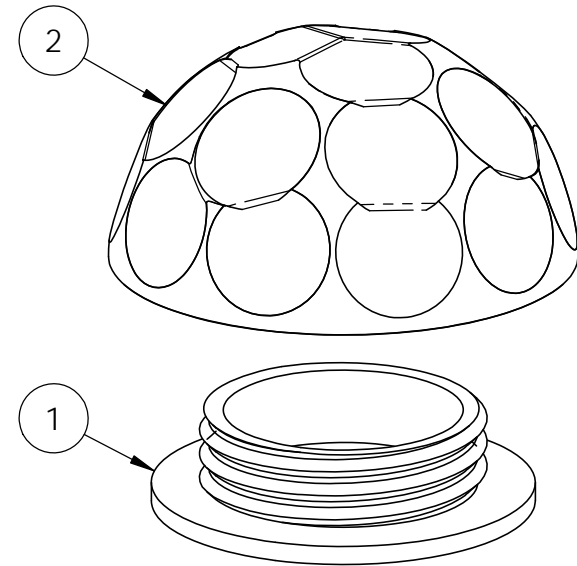
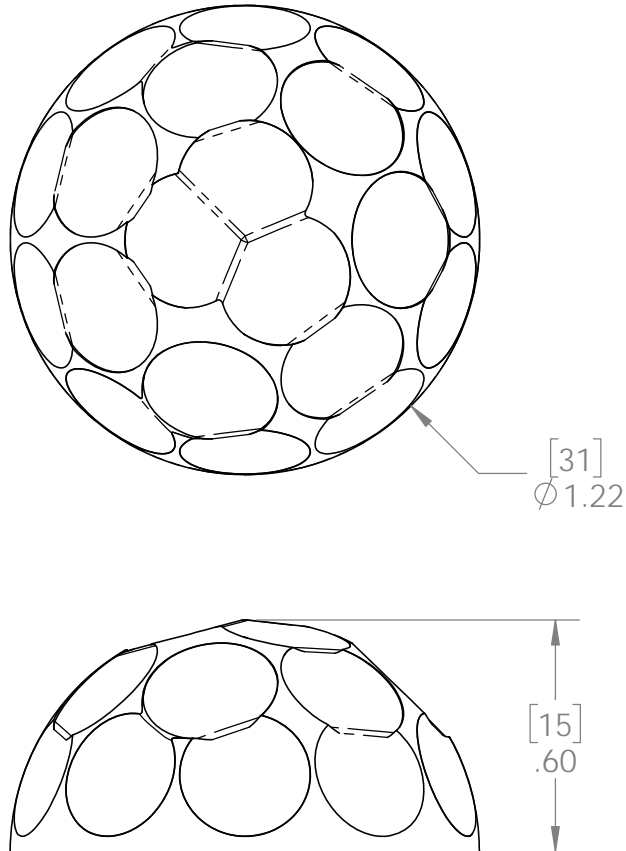

Weight: 0.05 LBS
 Scale: 2:1
 Last updated: 10/16/2016

56622-10

Product & Packaging Specs

1-1/4" Hammered Dome Cap Nut

Item #: 56622

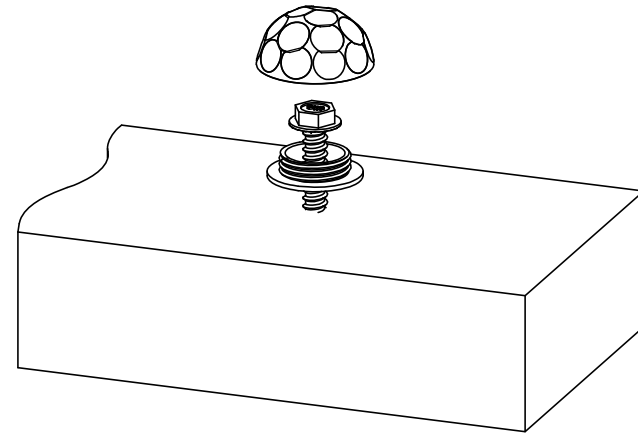
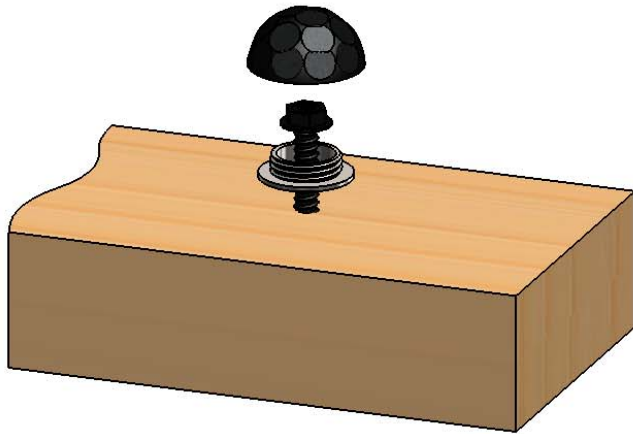
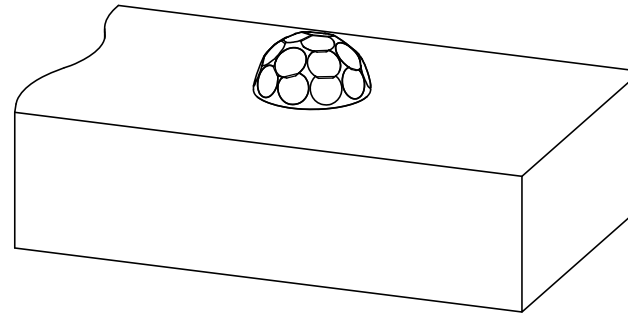
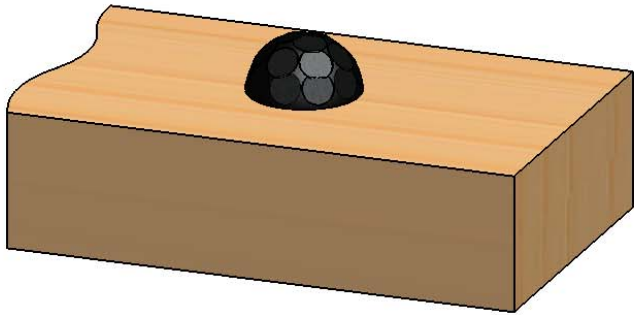

Weight: 0.05 LBS
Scale: 2:1
Last updated: 10/16/2016

56622-10

Product & Packaging Specs

1-1/4" Hammered Dome Cap Nut

Item #: 56622

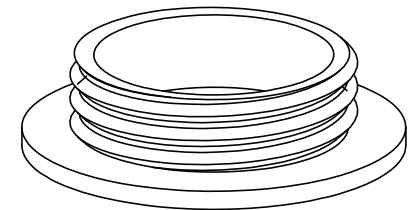
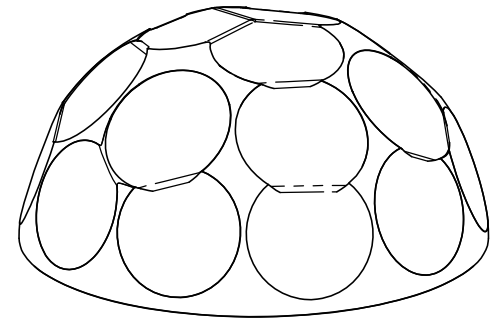
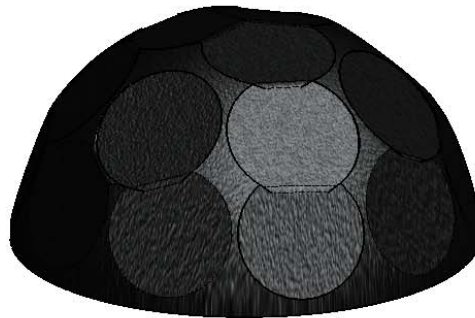
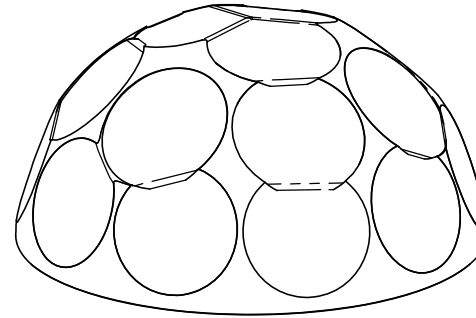
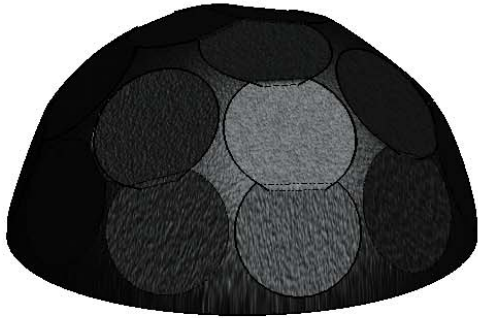

Weight: 0.05 LBS
Scale: 2:1
Last updated: 10/16/2016

56622-10



OZCO BUILDING PRODUCTS

Product & Packaging Specs

56622 Packing

Item #: Box packing



ITEM NO.	QTY.	PART NUMBER	DESCRIPTION
1	1	56622	1-1/4" Hammered Dome Cap Nut
2	1	Box, 56622	Box, DCN
3	1	Insert, DCN	Insert, DCN Box

Weight: 0.73 LBS
 Scale: 1:2
 Last updated: 10/16/2016

56622-10

Product & Packaging Specs

56622 Packing

Item #: Case packing



Weight: 14.4 LBS
 Scale: 1:3
 Last updated: 10/16/2016

56622-10



OZCO BUILDING PRODUCTS

Product & Packaging Specs

56622 Packing

Item #: Pallet packing

Item #: **56622** | **HDCN**

Hammered Dome Cap Nut

PALLET | **240 pcs**

SKU#: 56822



Made in China

Weight: 161 lbs

LOT# _____ Priority# _____



Total number of cases: 20
Total number of pieces:
20X12=240 pieces on pallet

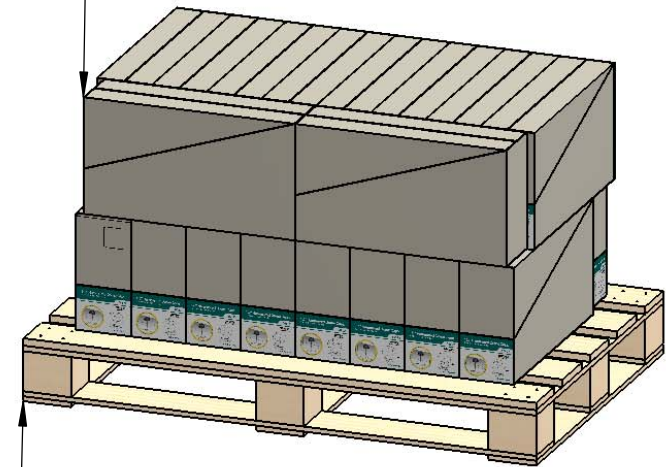

A pallet



additional pallet packing instructions

- plywood on top layer
- strap to pallet
- clear wrap around boxes

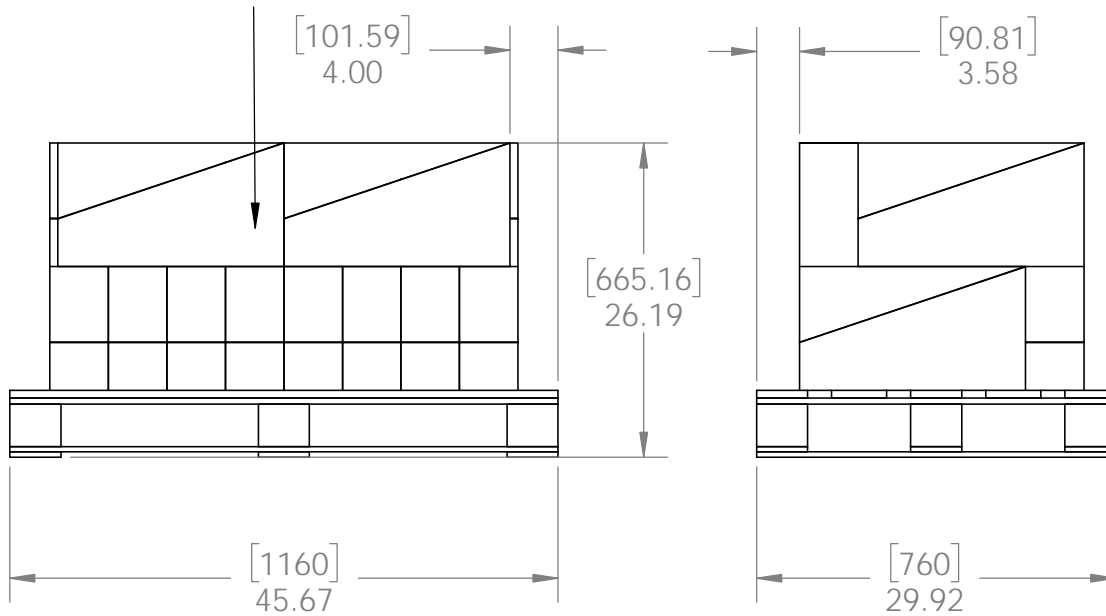

Weight: 161 LBS
Scale: 1:2
Last updated: 10/16/2016

56622-10

Product & Packaging Specs

86622 Packing

Item #: Blister Packing

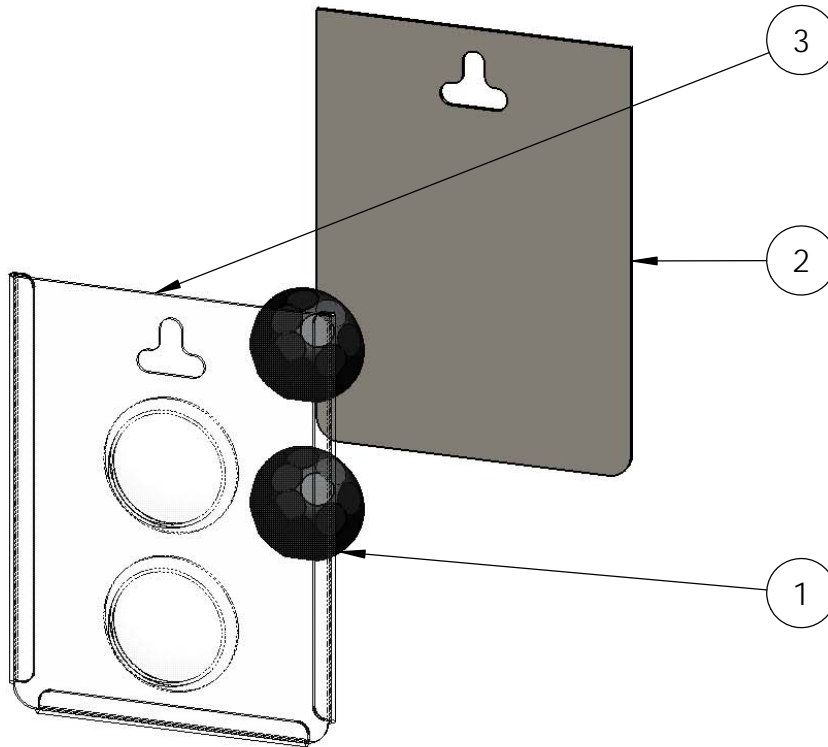

ITEM NO.	QTY.	PART NUMBER	DESCRIPTION
1	0.2	56622	1-1/4" Hammered Dome Cap Nut
2	1	Box, 86622	Box, 86622
3	1	Box, 86622	Box, 86622

Weight: 18.96 LBS
 Scale: 1:2
 Last updated: 10/16/2016

56622-10

Product & Packaging Specs

86622 Packing
Item #: Case Packing

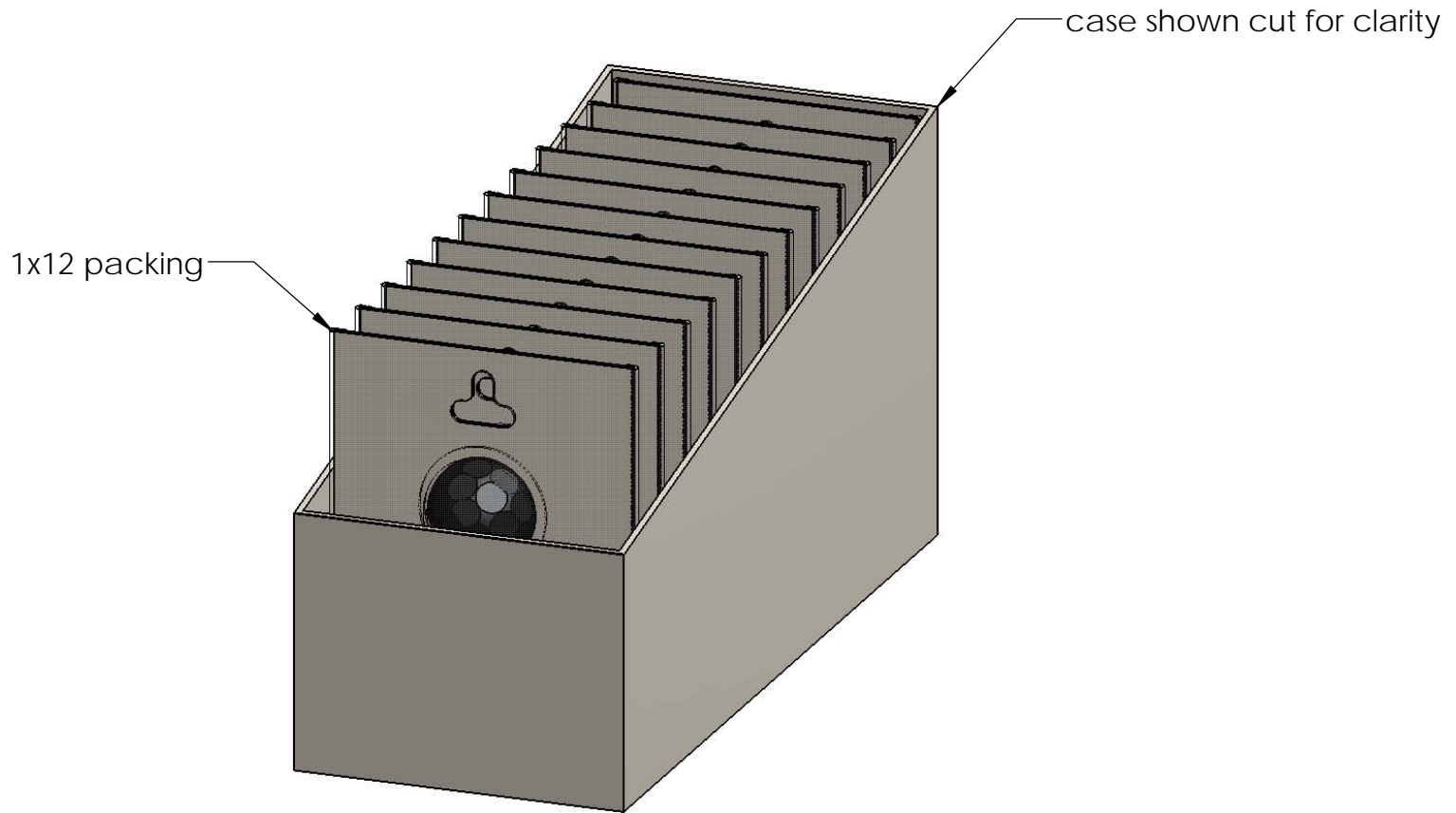

Weight: 18.96 LBS
Scale: 1:2
Last updated: 10/16/2016

56622-10

Product & Packaging Specs

86622 Packing
 Item #: Pallet Packing

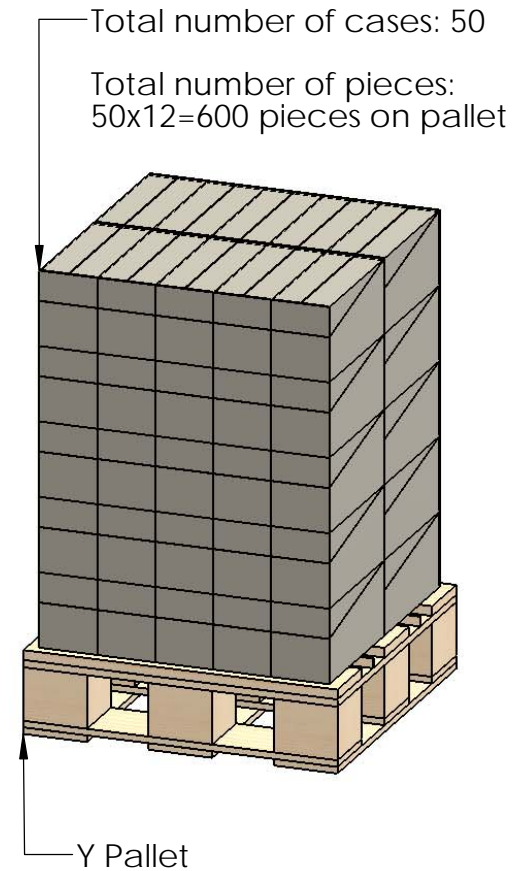
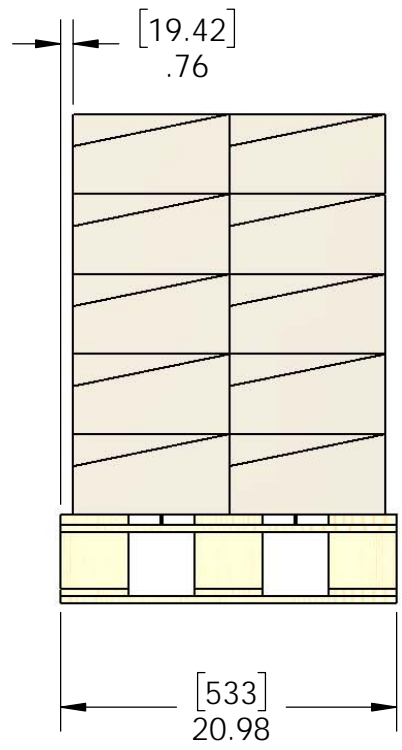
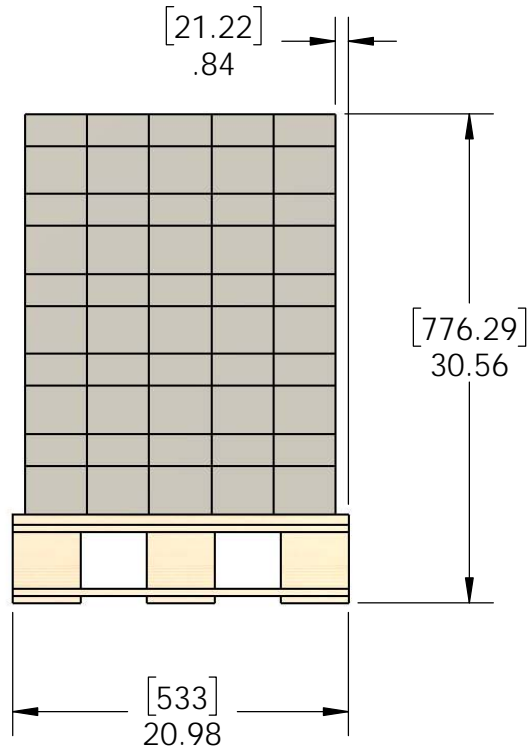

- additional pallet packing instructions
- plywood on top layer
 - strap to pallet
 - clear wrap around boxes

Weight: 110 LBS
 Scale: 1:12
 Last updated: 10/16/2016