

Installation Instructions, 56680

2" Timber Bolt Heavy Duty Washer (OWT-TBW-2)

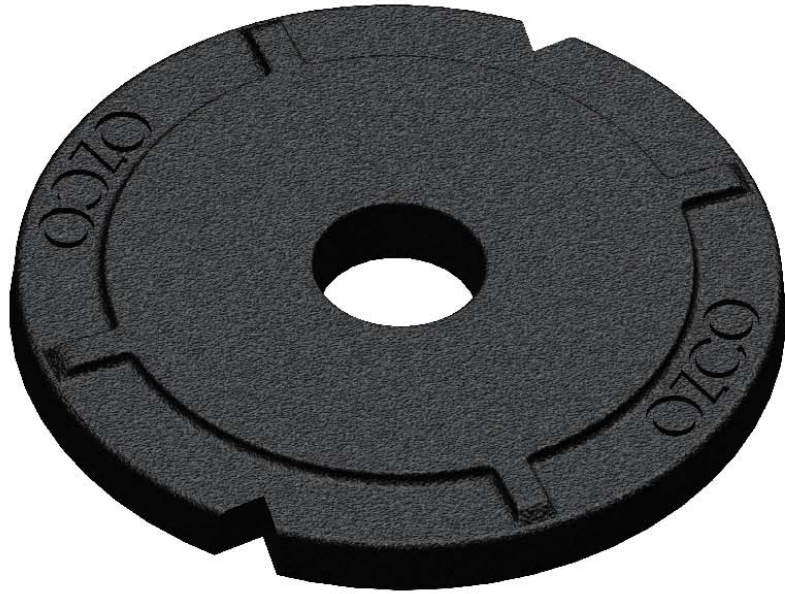

this product is an optional companion to OWT Timber Bolts. It's purpose to offer greater holding power with increased surface area.

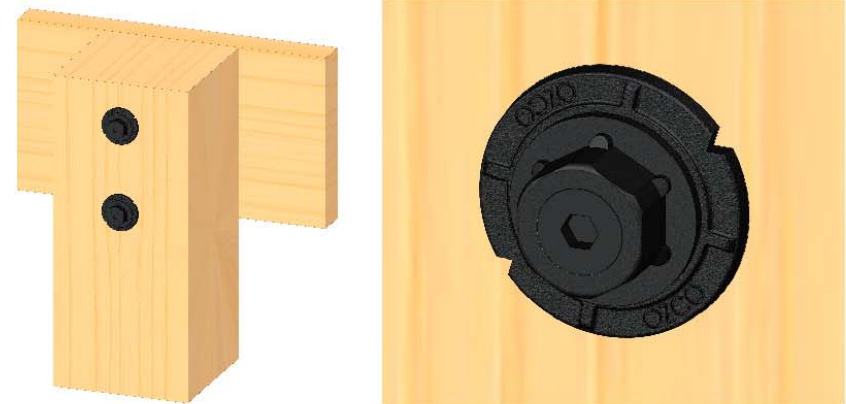

Typical Installation



OZCO BUILDING PRODUCTS ■ ■ ■

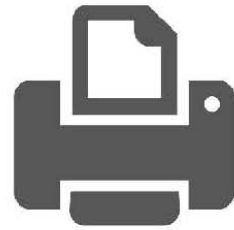

Printing Documents from ISSUU

Unfortunately, there is currently no way to print content directly through issuu. To print a publication, you will need to download it and print it from your computer.

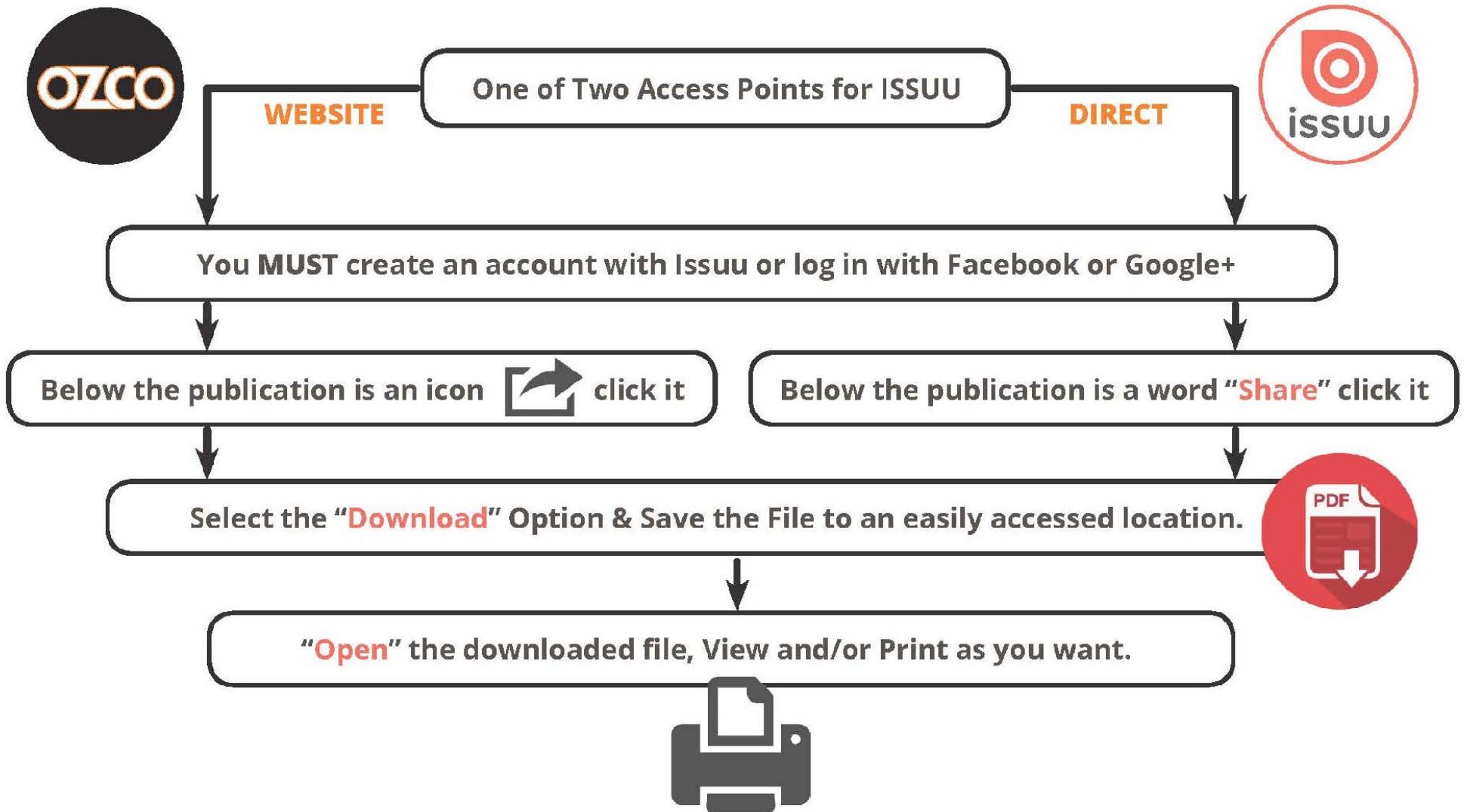

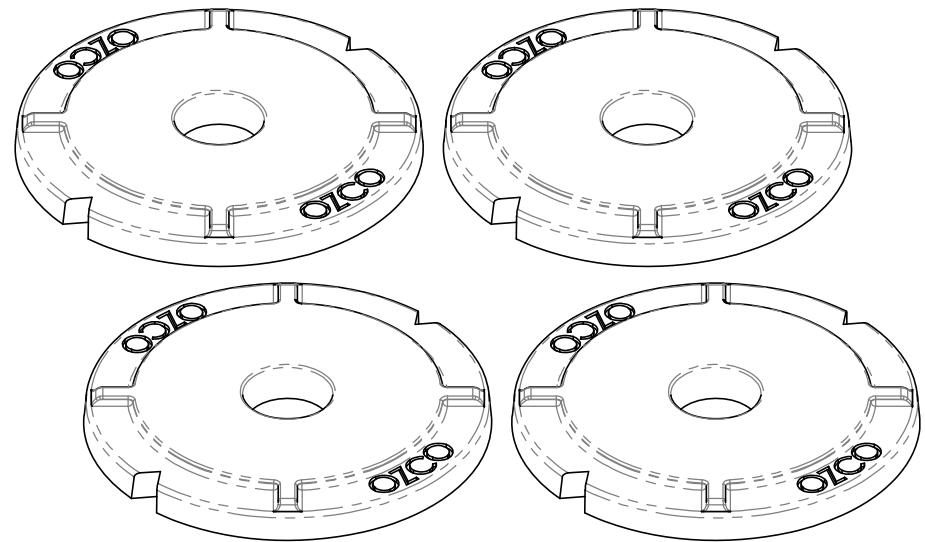
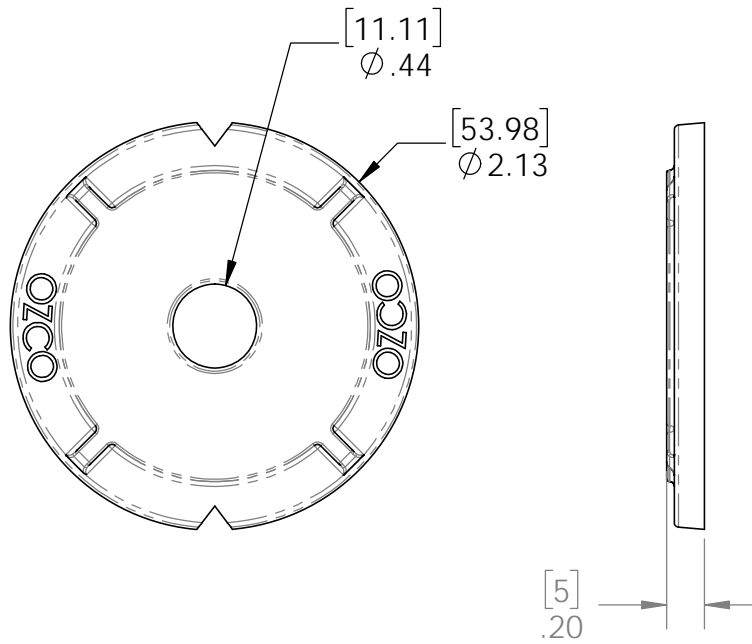

56680

Installation Instructions, 56680

see Installation Instructions,
OWT Timber Bolts BEFORE
proceeding

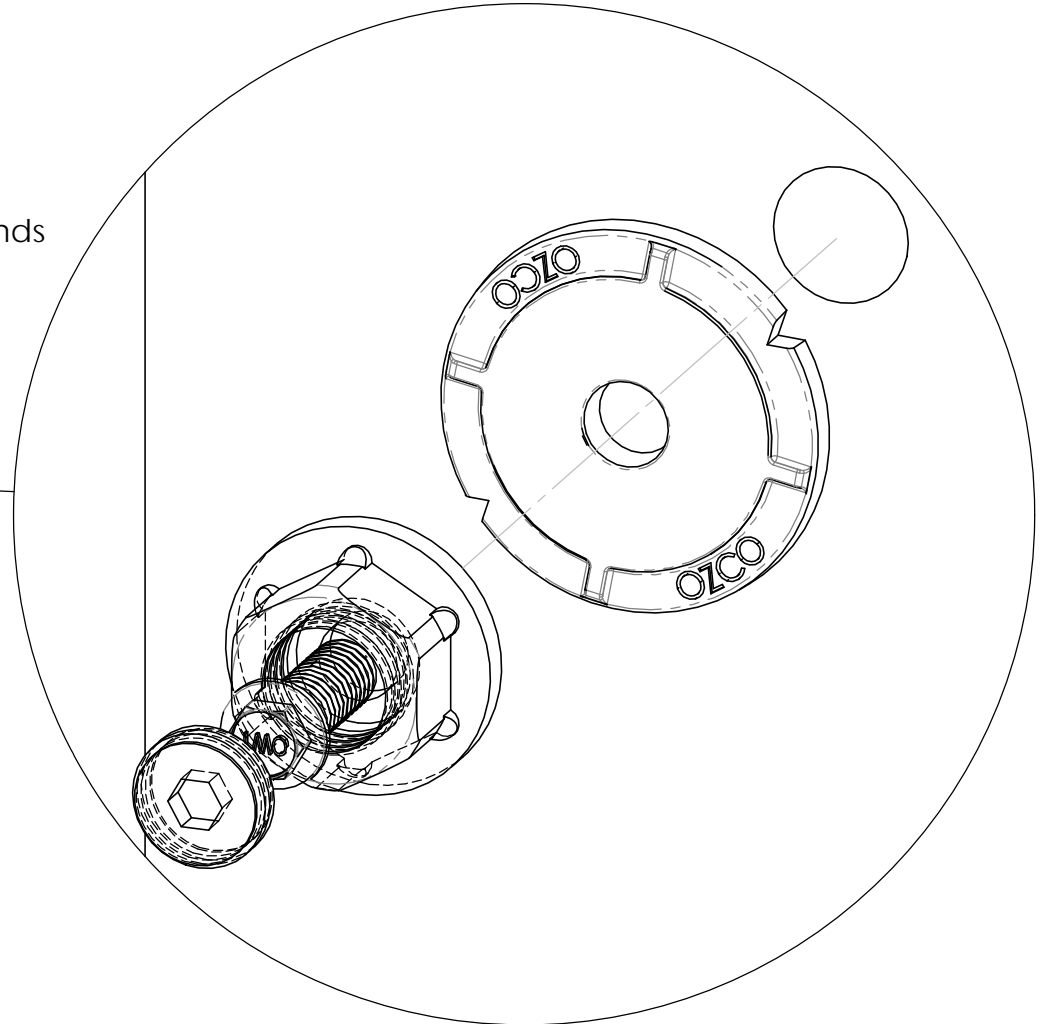
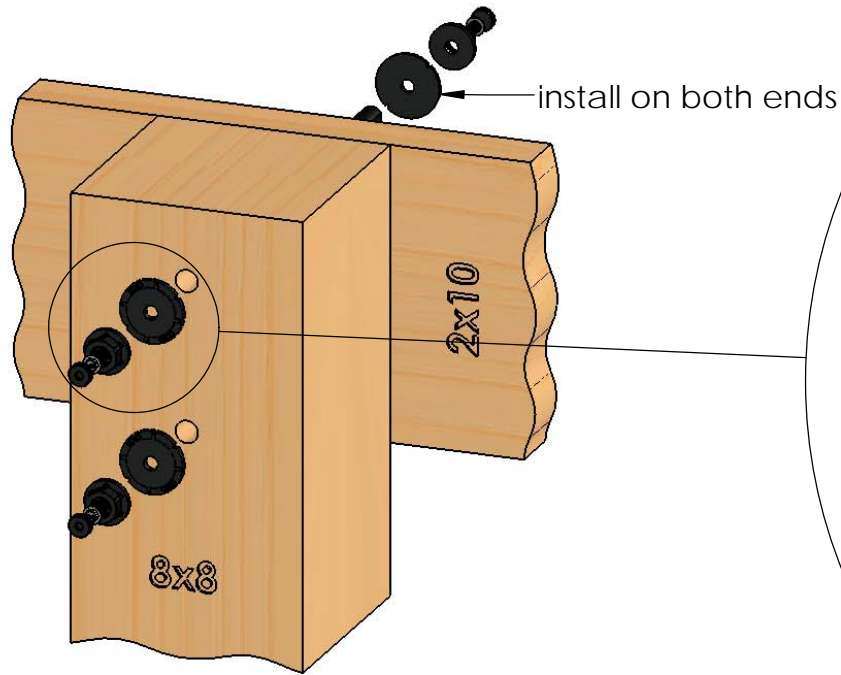

Typical Installation & Basic Assembly