

160 SW 12TH AVE SUITE 106, DEERFIELD BEACH, FL 33442
(954) 354-0660 | ENGINEERINGEXPRESS.COM

THIS DOCUMENT CONTAINS (2) PAGES: THE FIRST PAGE MUST BEAR AN ORIGINAL SIGNATURE & SEAL OF THE CERTIFYING PE TO BE VALID FOR USE

(Issued August 21, 2018 Subject to Renew August 21, 2020)
(or next code cycle change)

EVALUATION SUBJECT: **6-8" Joist Hanger Flush (JHF-68-LS) Item #: 56639**

TER-6757

2015 International Building Code

REPORT HOLDER:

OZCO BUILDING PRODUCTS
216 N. INTERURBAN
RICHARDSON, TEXAS 75081
(469) 916-7503 | OZCOBP.COM

SCOPE OF EVALUATION (compliance with the following codes):

This Product Evaluation Report is being issued in accordance with the requirements of the 2015 International Building Code for generic use within the state seal shown, per Section 104.11. The product noted on this report has been tested and/or evaluated as summarized herein. Re-evaluation of this product shall be required following pertinent International Building Code and local state code modifications or revisions.

SUBSTANTIATING DATA:

• **Product Test Reports**

Uplift and download forces and torsional moment for structural performance has been tested using the methods described by ASTM D 1761 Standard Test Methods for Mechanical Fasteners in Wood as per test report # D6706.01-119-16 by Architectural Testing, Inc (Report date: 06/13/14).

• **Structural Engineering Calculations**

Structural engineering calculations have been prepared which evaluate the product based on comparative and/or rational analysis to qualify the following design criteria:

- Maximum allowable uplift capacity
- Maximum allowable gravity capacity
- Maximum torsional moment capacity
- Anchor capacity

No 33% increase in allowable stress has been used in the design of this product.

INSTALLATION:

The product listed above shall be installed in strict compliance with the Product Evaluation Document (i.e. engineering drawing from the test report), along with all components noted therein.

The product components shall be of the material specified in the Product Evaluation Document. Bolts and screws must be installed in accordance with the applicable provisions in the NDS and anchor manufacturer's published installation instructions.

Full engagement shall be provided when connecting the steel flanges (lips) together for full capacity (leave 1/8" minimum length of uncovered lip past the outer steel plane surface).

LIMITATIONS & CONDITIONS OF USE:

Use of this product shall be in strict accordance with the Product Evaluation Documents as noted herein.

All supporting host structures shall be designed to resist all superimposed loads and shall be of a material listed in this report. Host structure conditions which are not accounted for in this product's respective anchor schedule shall be designed for on a site-specific basis by a registered Professional Engineer.

Adjustment factors noted herein and all applicable codes shall be considered by the installer, where applicable.

All components which are permanently installed shall be protected against corrosion, contamination, and other such damage at all times. Installer is responsible to protect against dissimilar materials.

Fasteners, including nuts and washers, for use in exterior conditions and in contact with preservative-treated wood or for fire-retardant-treated wood shall be of hot-dipped zinc-coated galvanized steel, stainless steel, silicon bronze or copper. Wood screws and lag screws shall be of mechanically deposited zinc-coated steel with coating weights in accordance with ASTM B 695, Class 55 minimum.

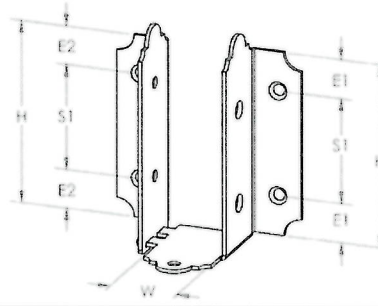

FACE MOUNT HANGERS FOR SOLID SAWN LUMBER

The face mount hanger architectural line provides an additional fastener to the bottom of joist and the final aesthetic finish, eliminating any further paint steps.

MATERIAL: Shall be 14 gauge steel (see Table 1) in accordance with ASTM A653 Grade 33 with minimum yield strength, $F_y = 33$ ksi and a minimum tensile strength, $F_u = 45$ ksi.

FINISH: Shall be comprised of powder coated, hot dip galvanized steel conforming to ASTM A153.

ORIGINAL SIGNATURE AND RAISED SEAL OR DIGITAL SEAL REQUIRED TO BE VALID PER CODE:

(Handwritten signature and blue circular seal)
Frank Bannardo PE
Texas 96064
F11383 COA

Frank L. Bannardo, P.E., SECB Signed by If Checked:
ENGINEERING EXPRESS®

PE # _____ PE # _____

NOTICE: IF THIS PAGE DOES NOT CONTAIN AN ORIGINAL SIGNATURE & ENGINEER SEAL: IF THERE IS A DIGITAL SIGNATURE ON PAGE 1, THIS DOCUMENT IS PART OF A DIGITALLY SIGNED FILE, SHALL REMAIN IN DIGITAL FORMAT & PRINTED COPIES OF THIS DOCUMENT ARE NOT CONSIDERED SIGNED AND SEALED. IF THERE IS NO DIGITAL SIGNATURE ON PAGE 1 OR THIS PAGE DOES NOT CONTAIN AN ENGINEER'S ORIGINAL SIGNATURE & SEAL, THIS DOCUMENT IS A COPY/DRAFT.

ABOUT THIS DOCUMENT
ENGINEER-CERTIFIED ORIGINALS, VARIATIONS & MORE INFORMATION CAN BE FOUND BY VISITING
ENGINEERINGEXPRESS.COM/STORE
OR BY SCANNING OR USING
THE WEB ADDRESS FOUND HERE >
THIS DOCUMENT NOT VALID WITHOUT ORIGINAL ENGINEER CERTIFICATION



INSTALLATION: Use all specified fasteners. Assembly kit includes fasteners for uniform finishing. See General Notes.

Face mount hangers listed below provide torsional resistance to prevent joist members from rotating about the longitudinal axis as much as 992 lbs-in (2"x8") and 329 lbs-in (2"x6") as per ICC-ES AC13 guidelines.

Use of face mount hangers with engineered wood products and different wood species other than those listed herein as Southern Yellow Pine (specific gravity, G=0.55) or Douglas Fir-Larch (specific gravity, G=0.50) are not covered under this report and shall be evaluated by redesigned Professional Engineer. 2"x6" minimum wood header size is required.

Install the two-part assembly providing full engagement of lips at bearing base to obtain full load capacity, 1/8" past outer steel plane, min.

OPTIONS: For specific scenarios contact OZCO for custom solutions. Extended bottom flange also available.

Table 1: 6-8" Joist Hanger Tab Capacities

MODEL NO.	POST SIZE	MATERIAL	DIMENSIONS (IN)						FASTENERS			ALLOWABLE LOADS - DF/SP (LBS)			
			W	H	E1	E2	S1	S2	ANCHOR		QTY.	UPLIFT (160)	FLOOR (100)	SNOW (115)	ROOF (125)
JHF-68-LS	2X6	14 Ga	1-9/16	4-1/16	13/16	1	2-1/4	2	HEADER	#12-10x1-1/4" Screws	4	213	188	216	235
									JOIST	#12-10x1-1/4" Screws	5				
JHF-68-LS	2X8	14 Ga	1-9/16	4-1/16	13/16	1	2-1/4	2	HEADER	#12-10x1-1/4" Screws	4	426	376	432	470
									JOIST	#12-10x1-1/4" Screws	5				

GENERAL NOTES:

1- The tabulated allowable loads shown are based on Allowable Stress Design (ASD) and loads have been increased for wind or earthquake loading, floor, snow or roof according to load duration factor, CD under the 2015 National Design Specification for Wood Construction (NDS) with no further increase allowed. Load reduction may apply where other loads govern.

2- Tabulated allowable loads shown apply to connections into wood used under dry conditions, with moisture content equal or less than 19% and where sustained temperatures are 100°F (37.8°C) or less. The allowable loads must be adjusted by the applicable factors for wet service conditions and higher temperatures in accordance with the National Design Specification for Wood Construction (NDS)

NOTES:

- 1- Uplift and gravity loads capacity shall be based on the member design calculated per code, not included in this evaluation report.
- 2- This product is not designed for welded or nailer applications.
- 3- Screws are provided with phillips heads with minimum bending yield strength for screws, Fyb = 80,000 psi and ultimate tensile strength, Fu = 74,000 psi, 1-1/8" thread penetration.
- 4- Designer shall consider effects on strength of lumber from new preservative treatments or fire-retardant treatments other than under National Design Specification for Wood Construction (NDS).
- 5- Screw penetration is into solid wood and does not include thickness of any finishes.

LIMITATIONS & CONDITIONS OF USE:

Use of this product shall be in strict accordance with this TER as noted herein. The supporting host structure shall be designed to resist all superimposed loads as determined by others on a site specific basis as may be required by the Authority Having Jurisdiction. Host structure conditions which are not accounted for in this product's respective anchor schedule shall be designed for on a site-specific basis by a registered professional engineer. No evaluation is offered for the host supporting structure by use of this document; Adjustment factors noted herein and the applicable codes must be considered, where applicable. All supporting components which are permanently installed shall be protected against corrosion, contamination, and other such damage at all times. Fasteners must penetrate the supporting members such that the full length of the threaded portion is embedded within the main member.

IN ALL CONDITIONS IT IS THE RESPONSIBILITY OF THE PERMIT HOLDER TO ENSURE THE HOST STRUCTURE IS CAPABLE OF WITHSTANDING THE RATED GRAVITY, LATERAL, AND UPLIFT FORCES BY SITE-SPECIFIC DESIGN. NO WARRANTY OF ANY KIND, EXPRESSED OR IMPLIED, IS OFFERED BY THIS ENGINEER AS TO THE INTEGRITY OF THE HOST STRUCTURE TO CARRY DESIGN FORCE LOADS INCURRED BY THIS UNIT.