



OZCO BUILDING PRODUCTS

Product & Packaging Specs

Post to Beam Bolt Offset (P2B-BO-IW)

Item #: 51736

ITEM NO.	QTY.	PART NUMBER	DESCRIPTION
1	0.2	56621	1 1/2" Hex Cap Nut (HCN)
2	0.08	56626	OWT Timber Screw 2-3/4"
3	1	51710-11	Ledge, Post to Beam
4	1	51736-11	Plate, Top Bolt Offset

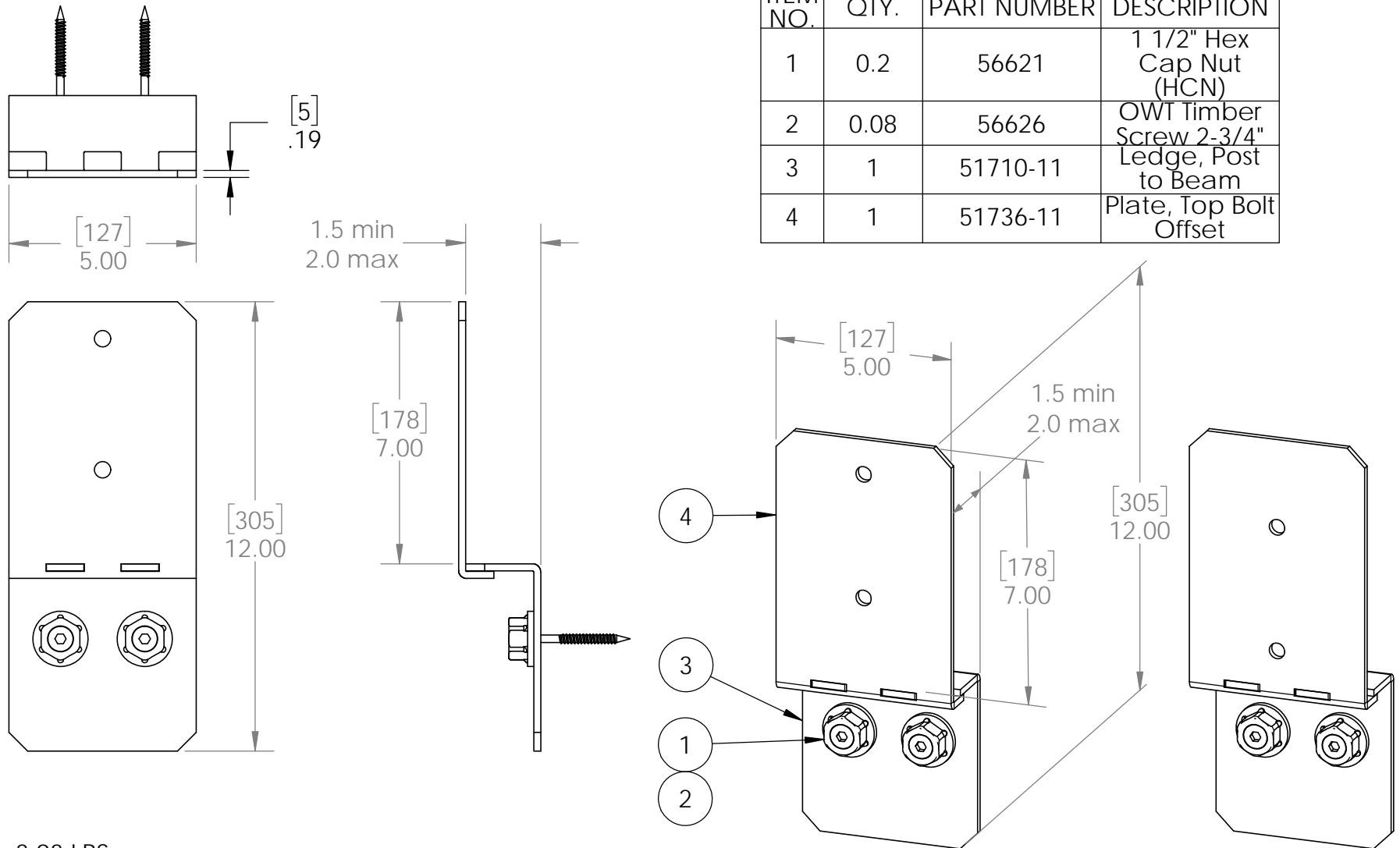

Weight: 3.93 LBS
 Scale: 1:4
 Last updated: 10/10/2016

51736

Product & Packaging Specs

Post to Beam Bolt Offset (P2B-BO-IW)

Item #: Typical Installation & Basic Assembly

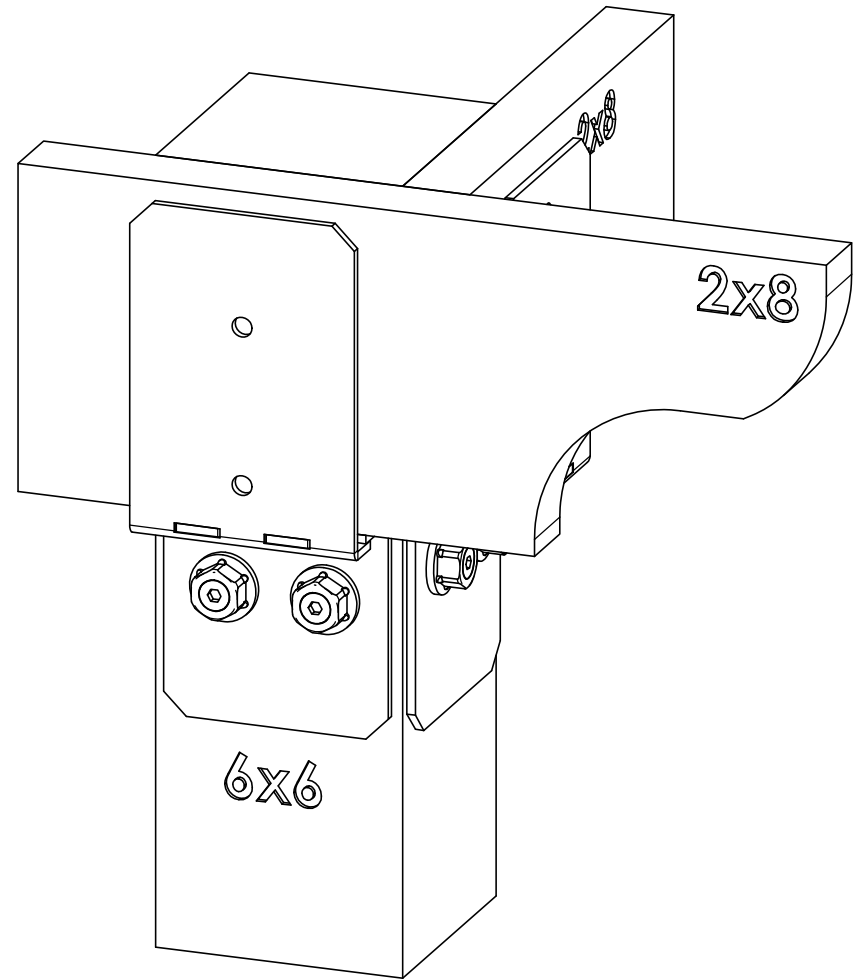
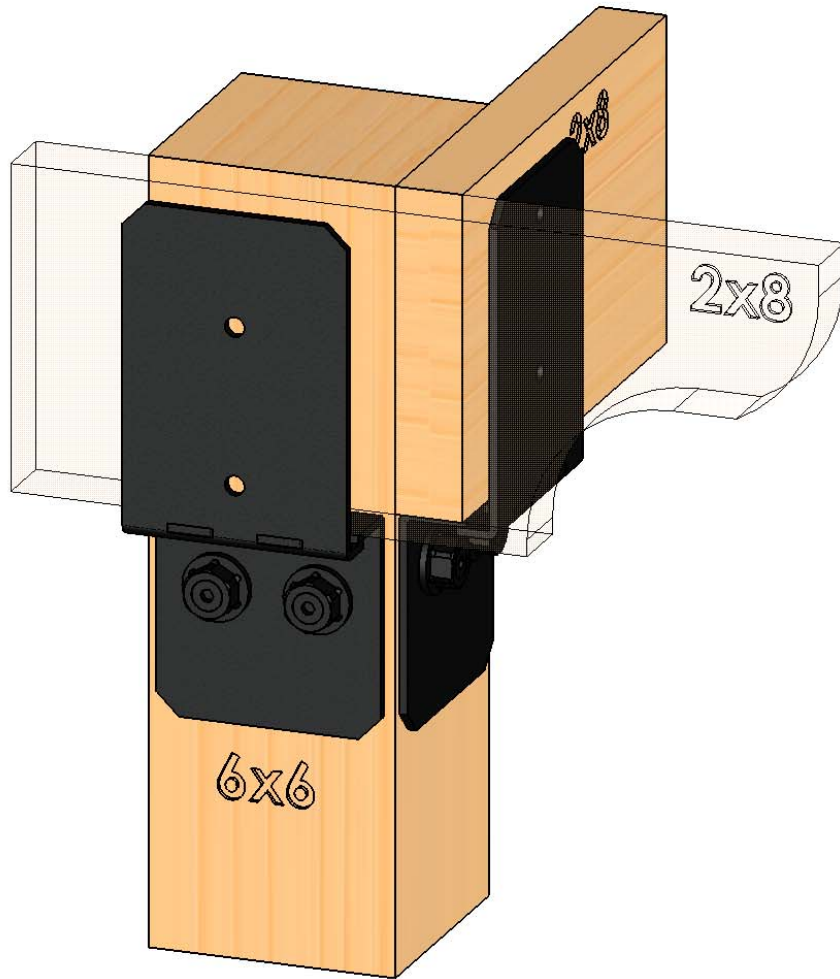

Weight: 3.93 LBS
Scale: 1:4
Last updated: 10/10/2016

51736

Product & Packaging Specs

Post to Beam Bolt Offset (P2B-BO-IW)

Item #: Typical Installation & Basic Assembly

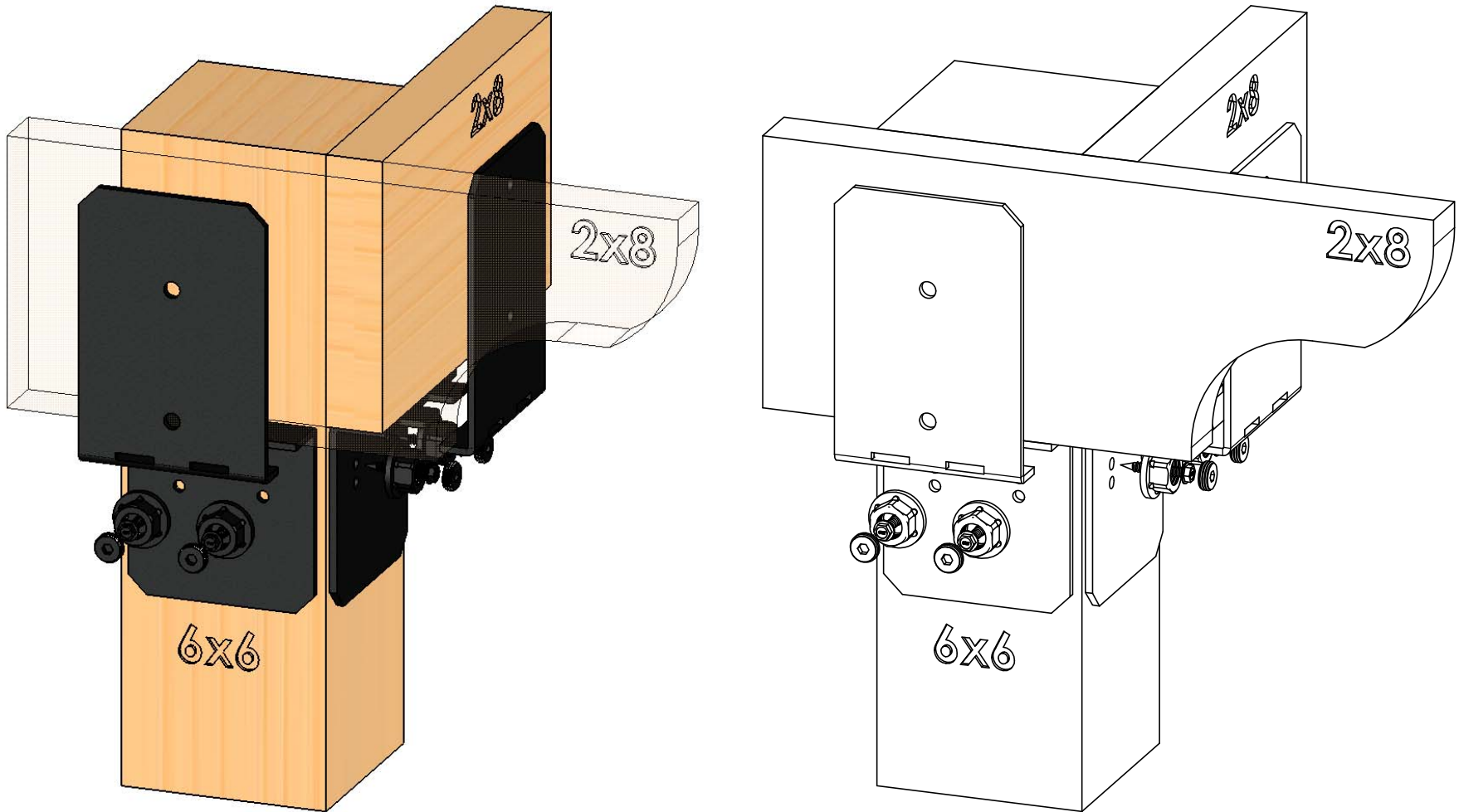

Weight: 3.93 LBS
Scale: 1:4
Last updated: 10/10/2016

51736



OZCO BUILDING PRODUCTS

Product & Packaging Specs

Post to Beam Bolt Offset (P2B-BO-IW)

Item #: Typical Installation & Basic Assembly

TIMBER BOLTS SOLD SEPARATELY

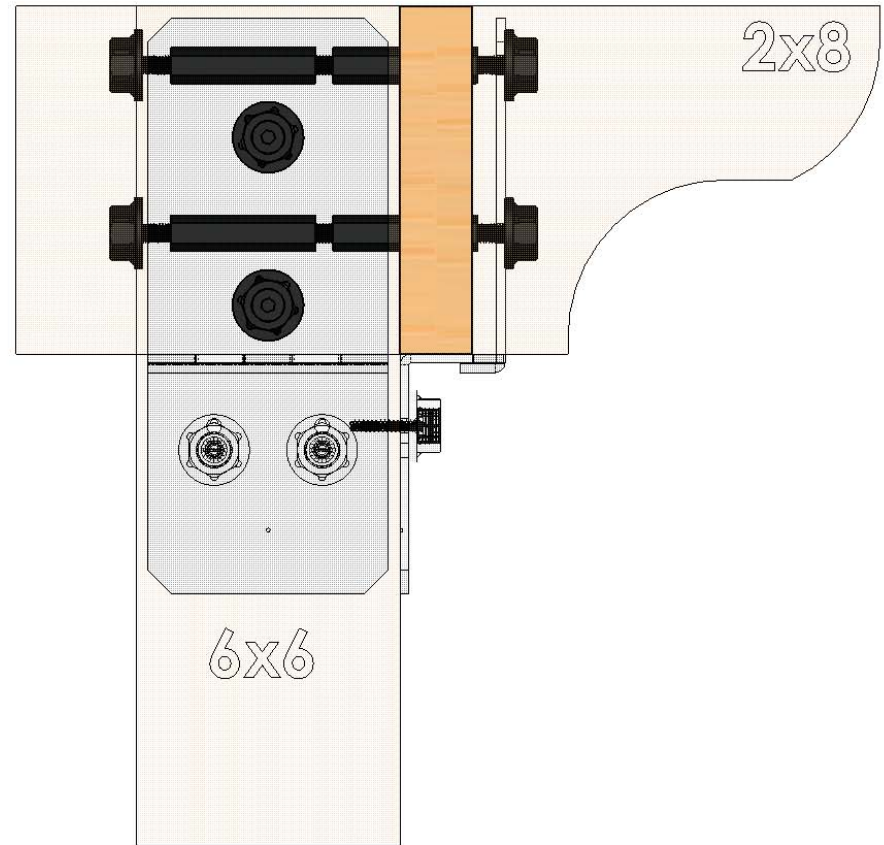
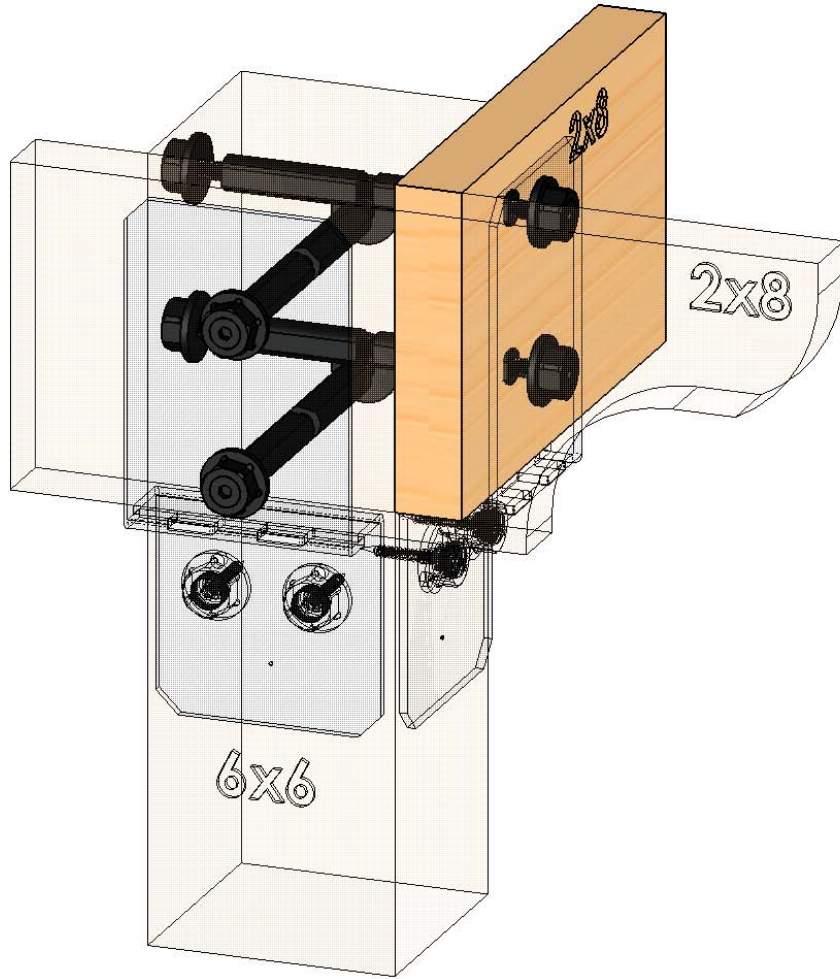

Weight: 39.31 LBS
Scale: 1:4
Last updated: 10/10/2016

51736

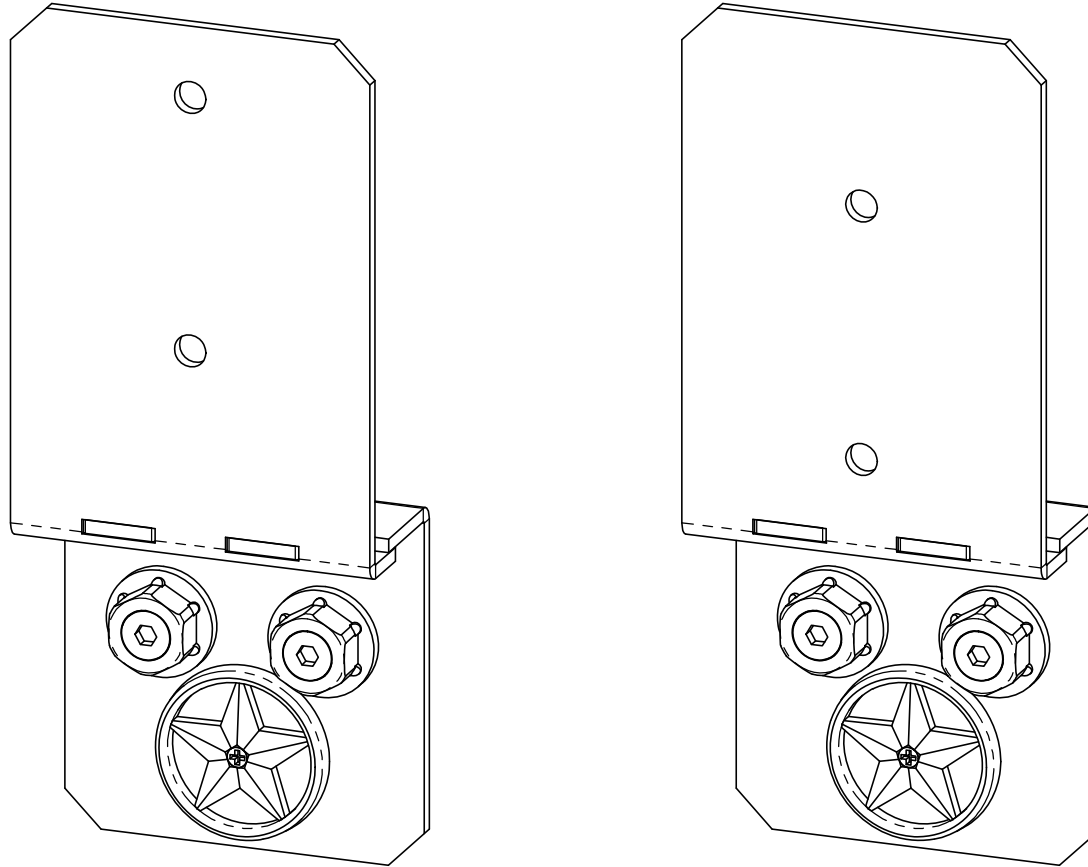

Weight: 3.93 LBS
Scale: 1:2.5
Last updated: 10/10/2016

51736

Product & Packaging Specs

Post to Beam Bolt Offset (P2B-BO-IW)

Item #: 51736

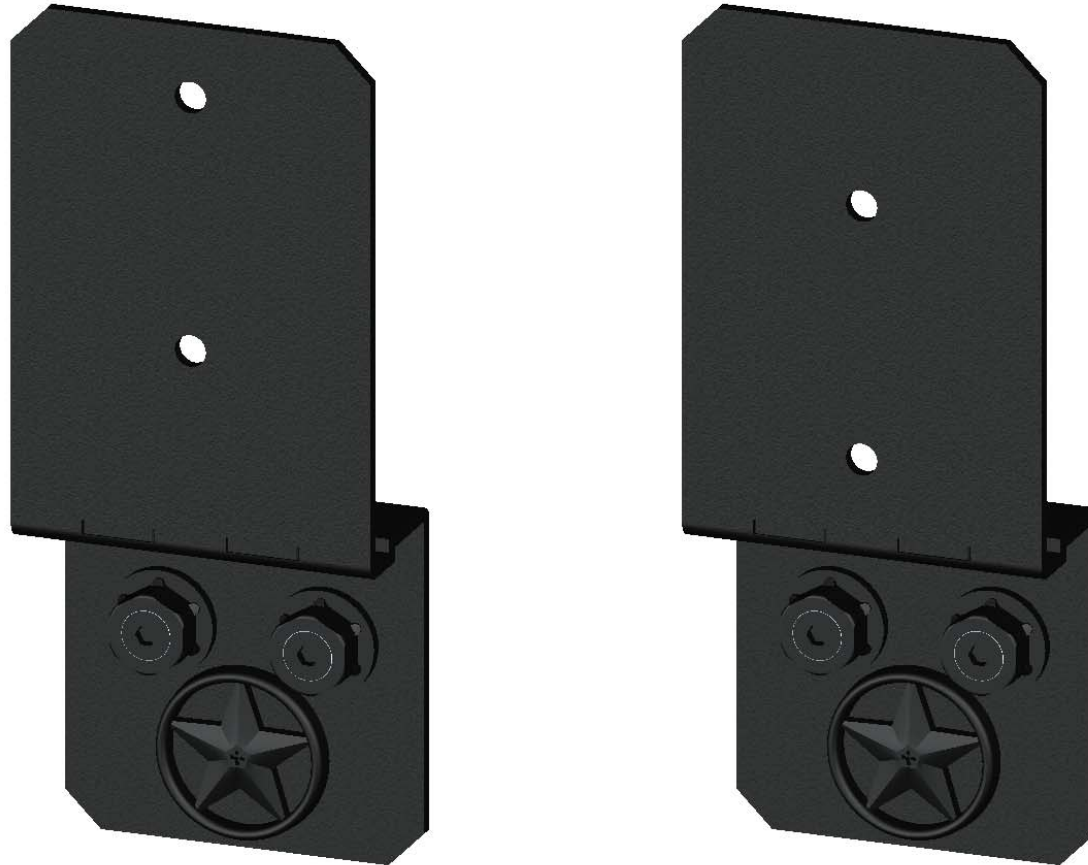

Weight: 3.93 LBS
Scale: 1:2.5
Last updated: 10/10/2016

51736



OZCO BUILDING PRODUCTS

Product & Packaging Specs

Post to Beam Bolt Offset (P2B-BO-IW)

Item #: Typical Installation & Basic Assembly

TIMBER BOLTS & STARS SOLD SEPARATELY

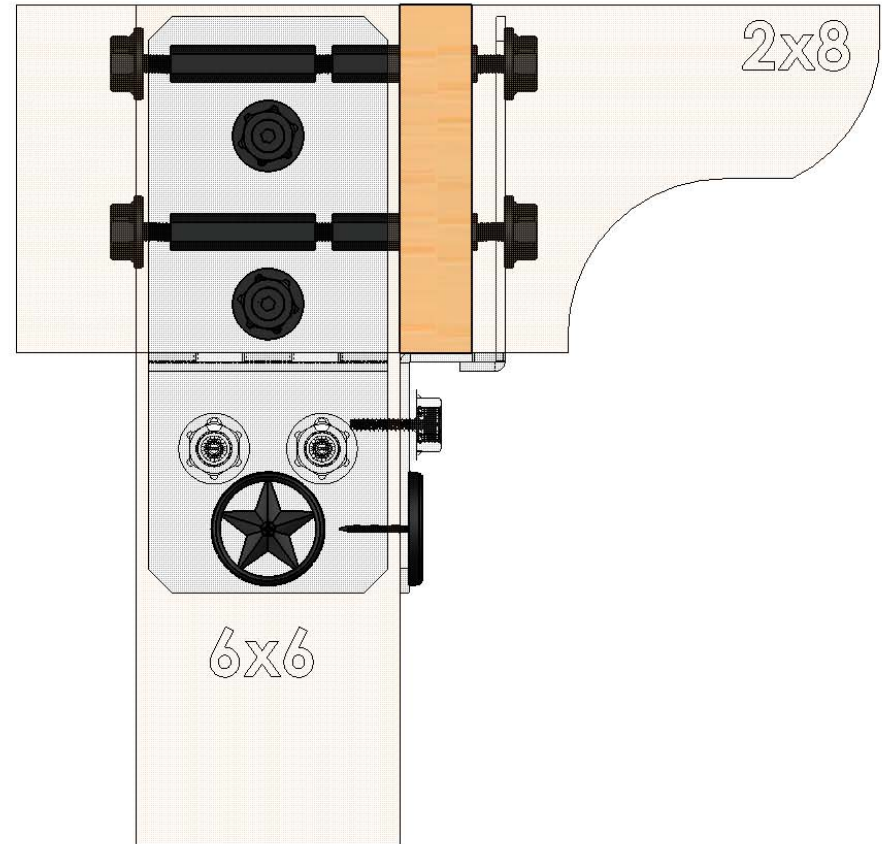
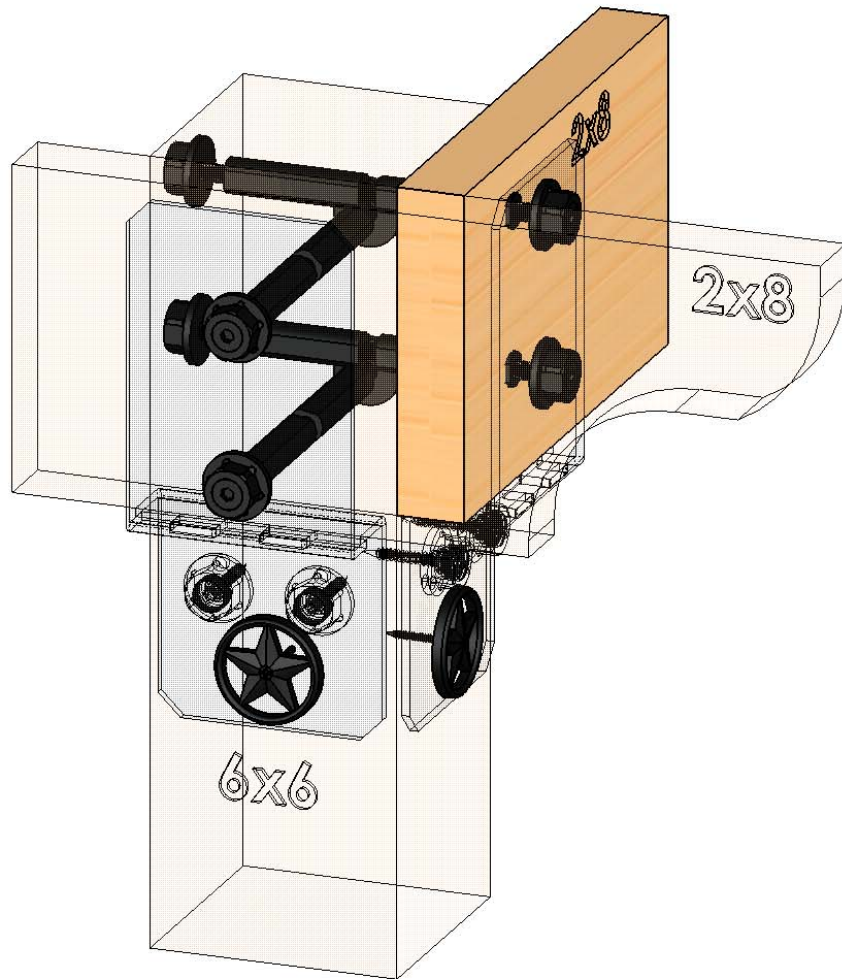

Weight: 39.31 LBS
Scale: 1:2.5
Last updated: 10/10/2016

51736



OZCO BUILDING PRODUCTS

Product & Packaging Specs

51736 Packing

Item #: Box packing

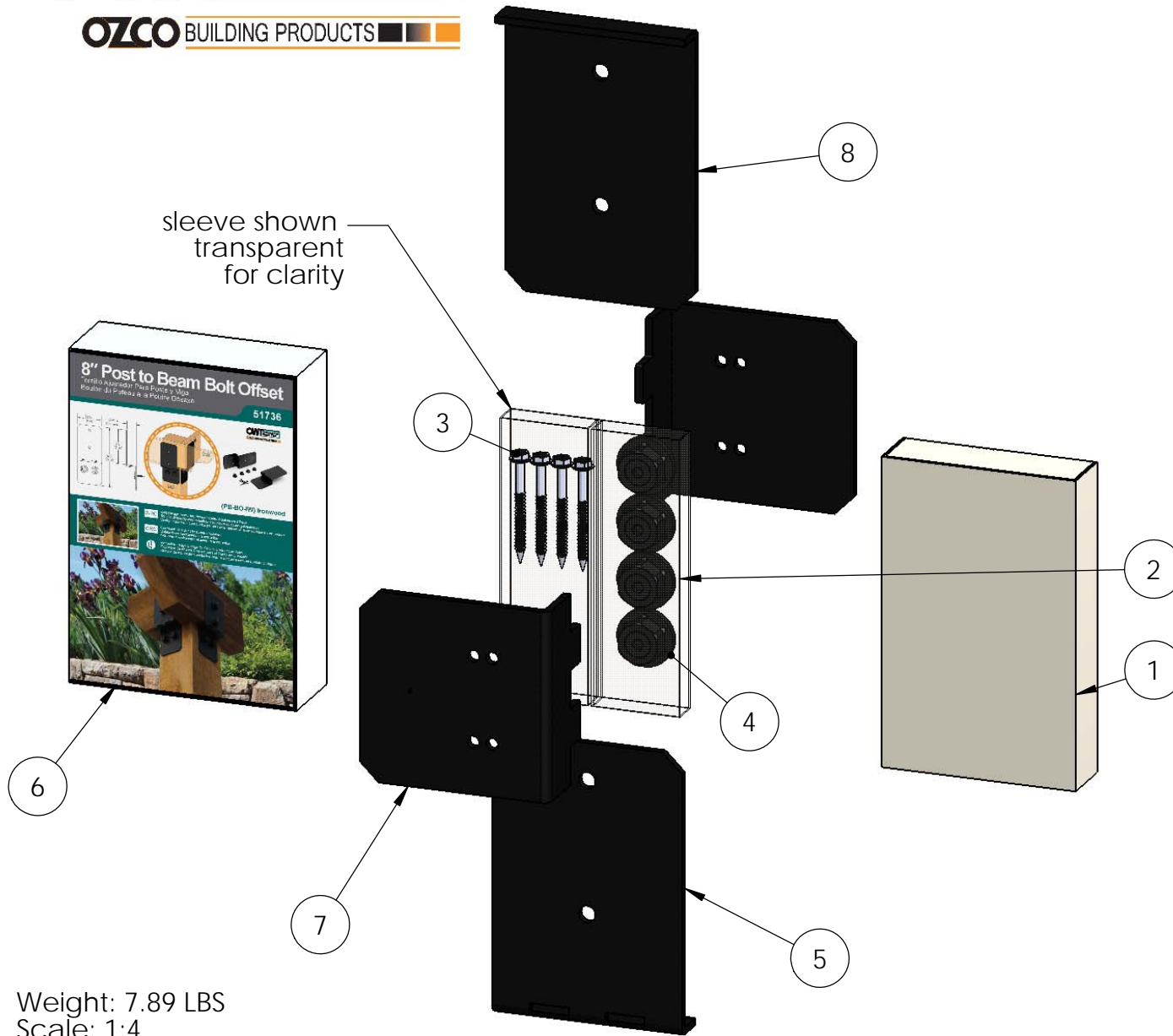

ITEM NO.	QTY.	PART NUMBER	DESCRIPTION
1	1	56637 Inner Box	56637 Inner Box
2	1	56637 Inner Box Sleeve	56637 Inner Box Sleeve
3	4	56626	OWT Timber Screw 2-3/4 (70mm)
4	0.4	56621	1 1/2" Hex Cap Nut (HCN)
5	1	51736-11	Plate, Top Bolt Offset
6	1	Box, 51736	Box, 51736
7	2	51710-11	Ledge, Post to Beam
8	1	51737-11	Plate, Bolt Inline

Weight: 7.89 LBS
 Scale: 1:4
 Last updated: 10/10/2016

51736

Product & Packaging Specs

51736 Packing

Item #: Case packing

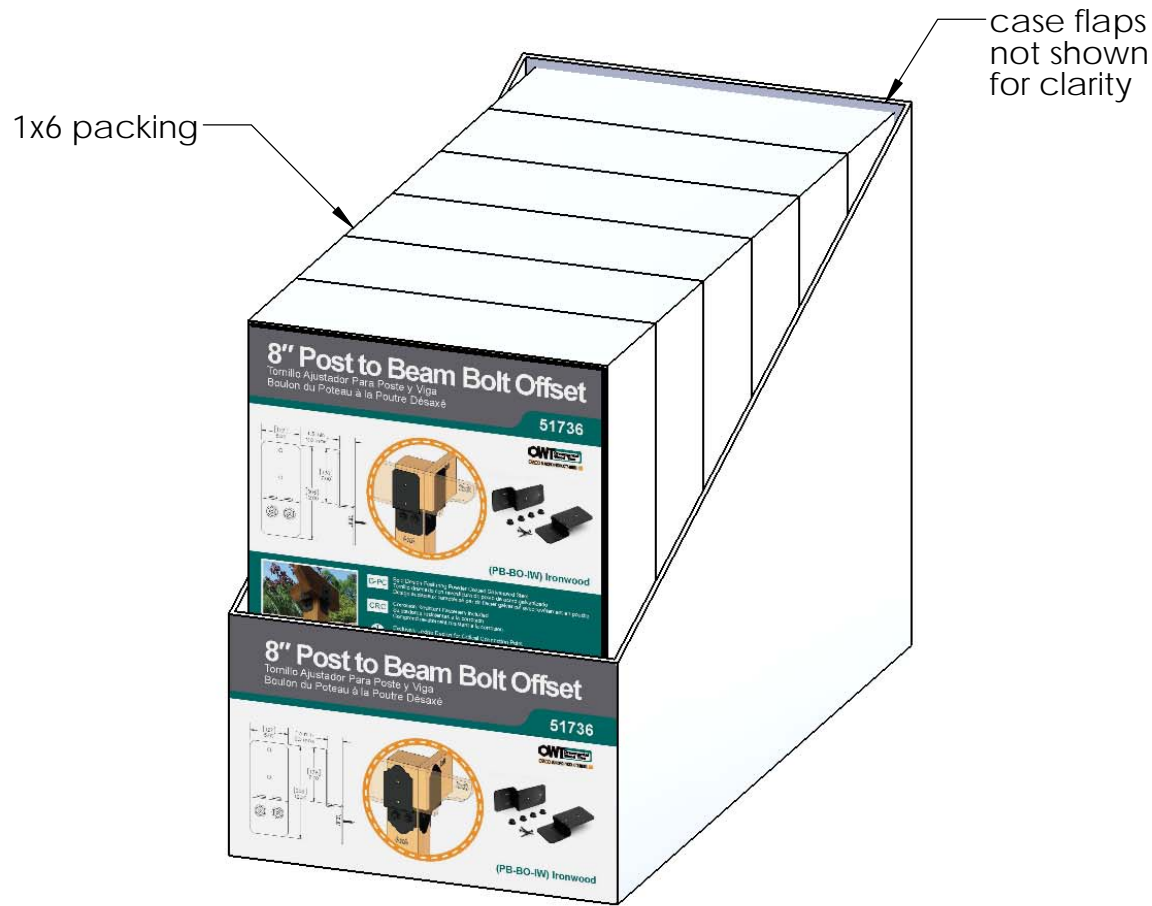

Weight: 45 LBS
 Scale: 1:3
 Last updated: 10/10/2016

51736

Product & Packaging Specs

51736 Packing
 Item #: Pallet packing

ADD PALLET LABEL

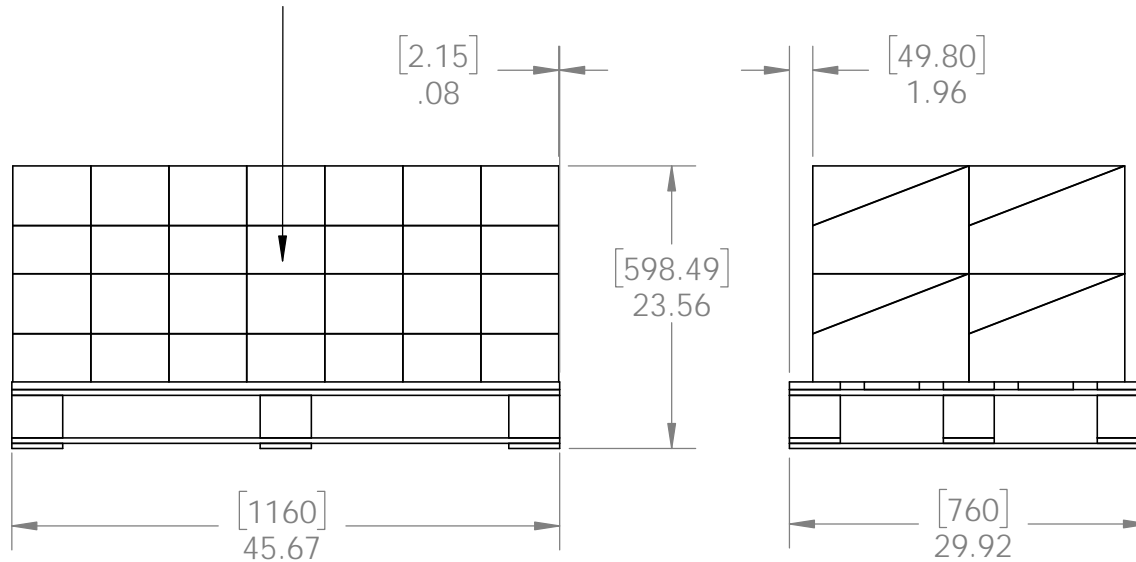

Total number of cases: 28
 Total number of pieces:
 28x6=168 pieces on pallet

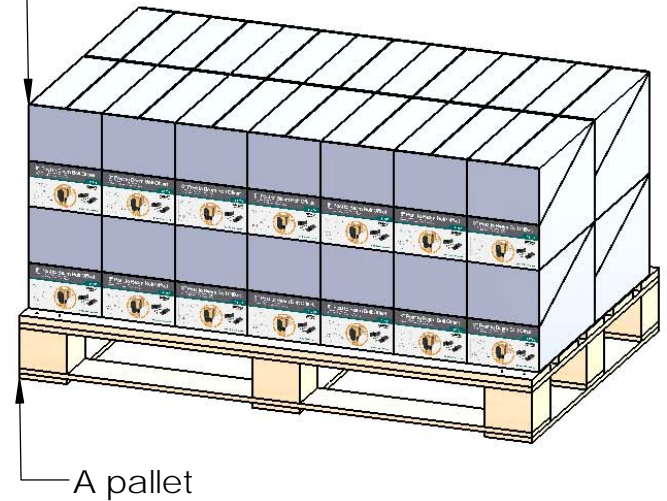

additional pallet packing instructions

- plywood on top layer
- strap to pallet
- clear wrap around boxes

Weight: 1340 LBS
 Scale: 1:16
 Last updated: 10/10/2016

51736