

Product & Packaging Specs

2" Standard Rafter Clips (RC-IW-2)

Item #: 51717

ITEM NO.	QTY.	PART NUMBER	DESCRIPTION
1	2	80060	Screw, 1-1/2"x1/4" Black Hex-Head (1-1/2-HX-SCR)
2	1	51717-11	Clip, 2" Rafter

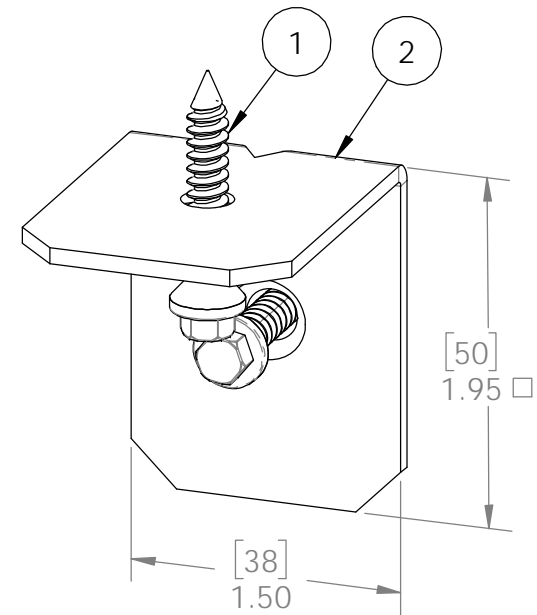
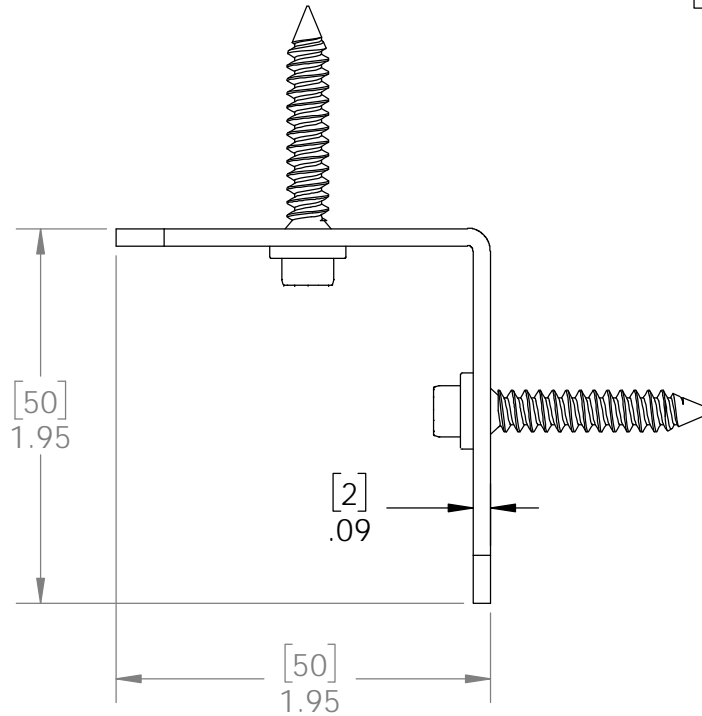
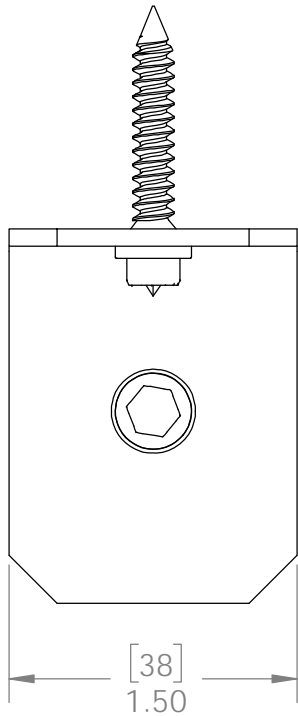

Weight: 0.14 LBS
 Scale: 1:1
 Last updated: 12/14/2017

51717

Product & Packaging Specs

2" Standard Rafter Clips (RC-IW-2)

Item #: 51717

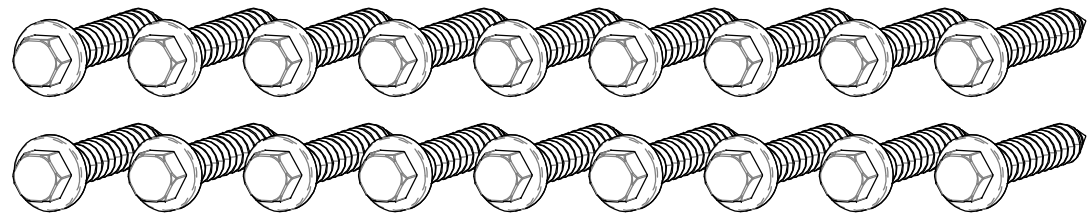
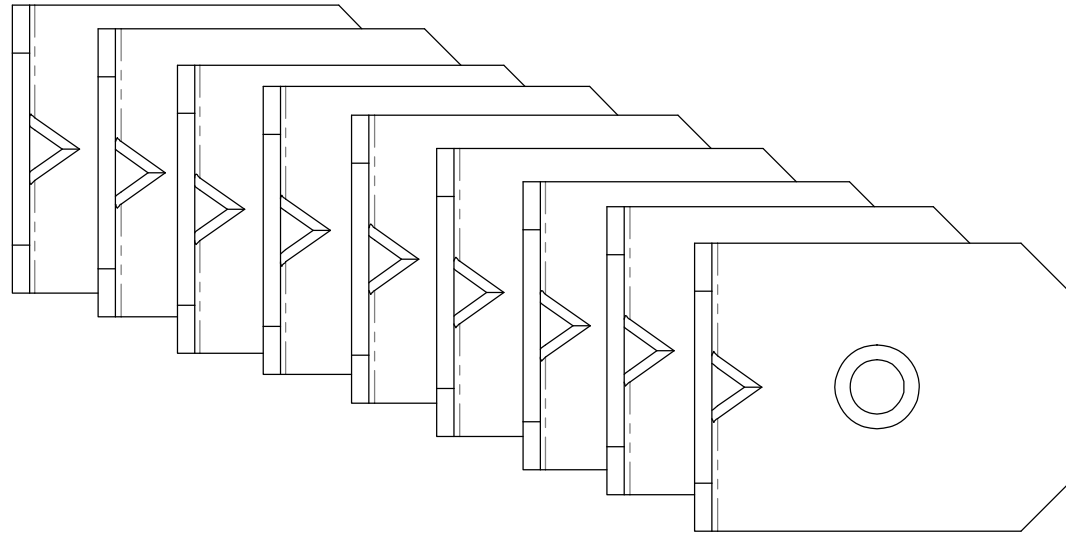
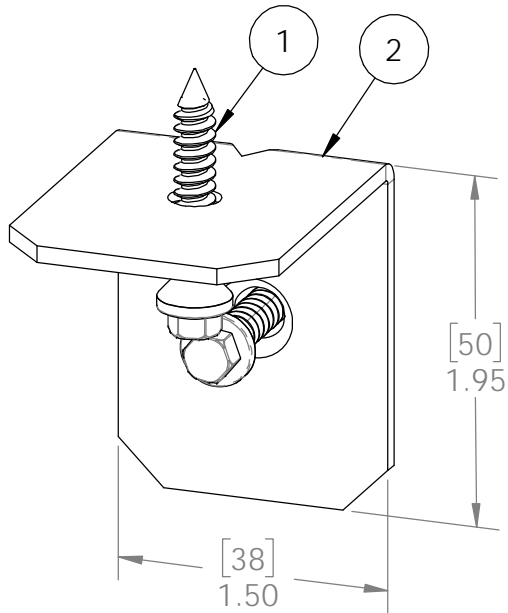

Weight: 0.14 LBS
 Scale: 1:1
 Last updated: 12/14/2017

51717

Product & Packaging Specs

2" Standard Rafter Clips (RC-IW-2)

Item #: Typical Installation & Basic Assembly

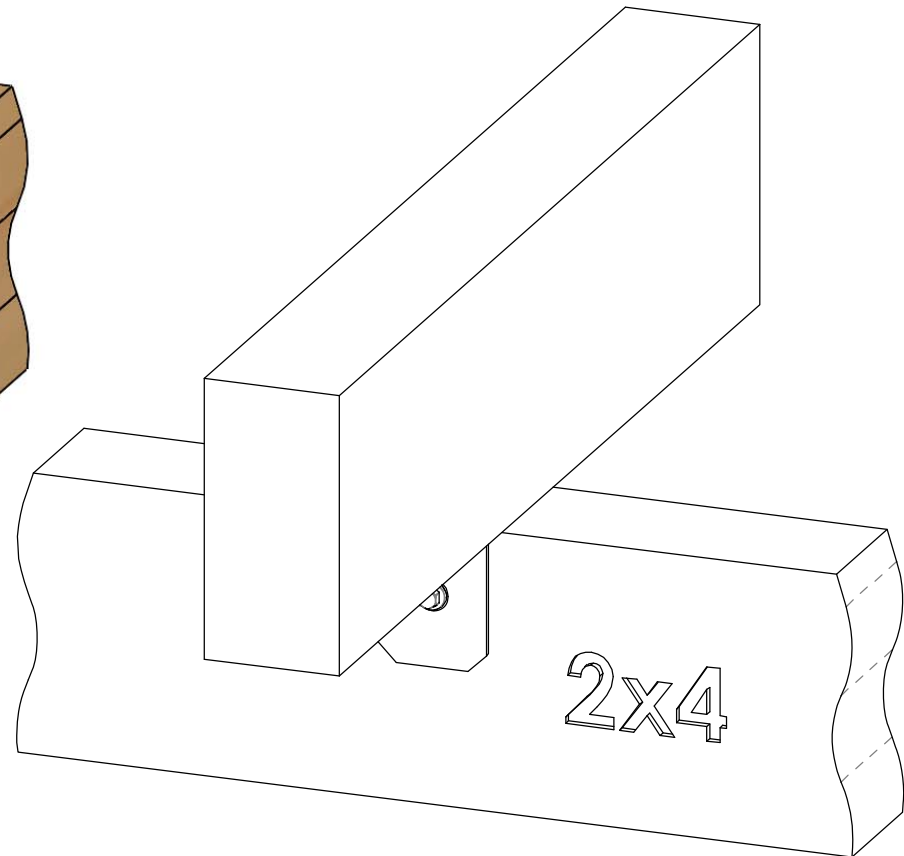
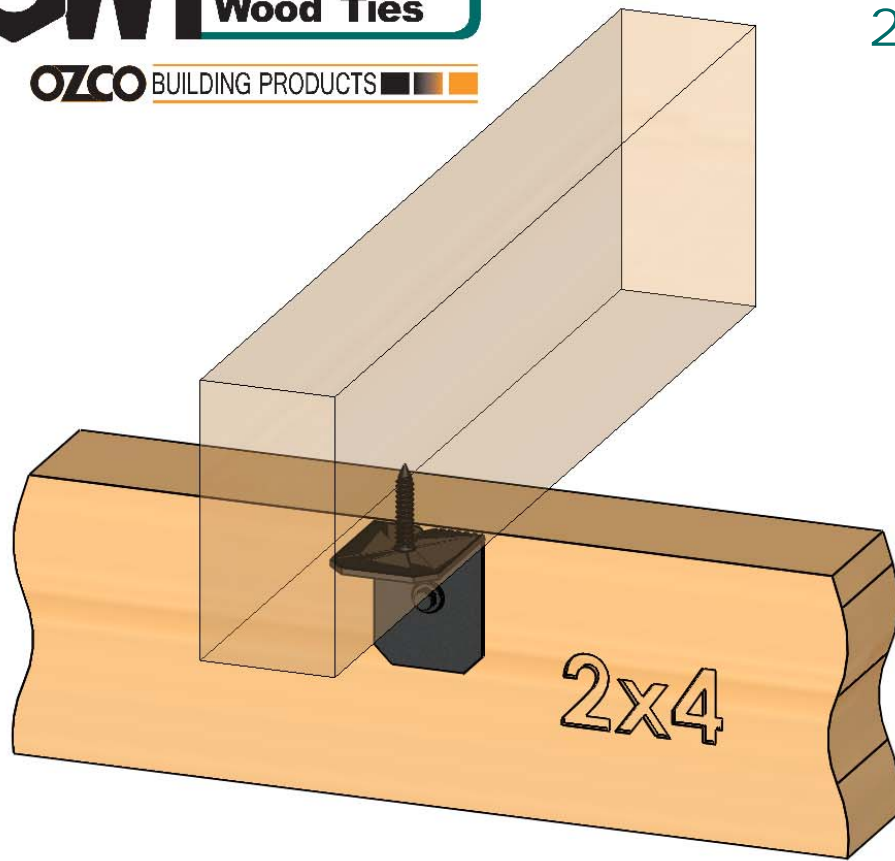

Scale: 1:2.5
Last updated: 12/14/2017

51717

Product & Packaging Specs

2" Standard Rafter Clips (RC-IW-2)

Item #: Typical Installation & Basic Assembly

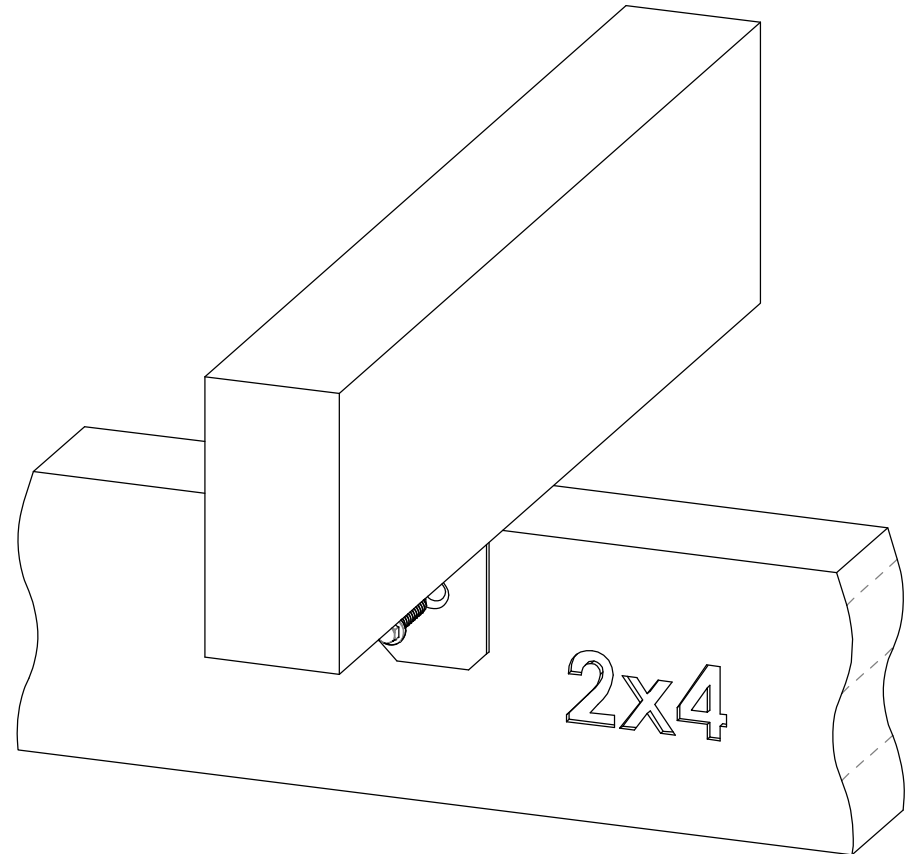
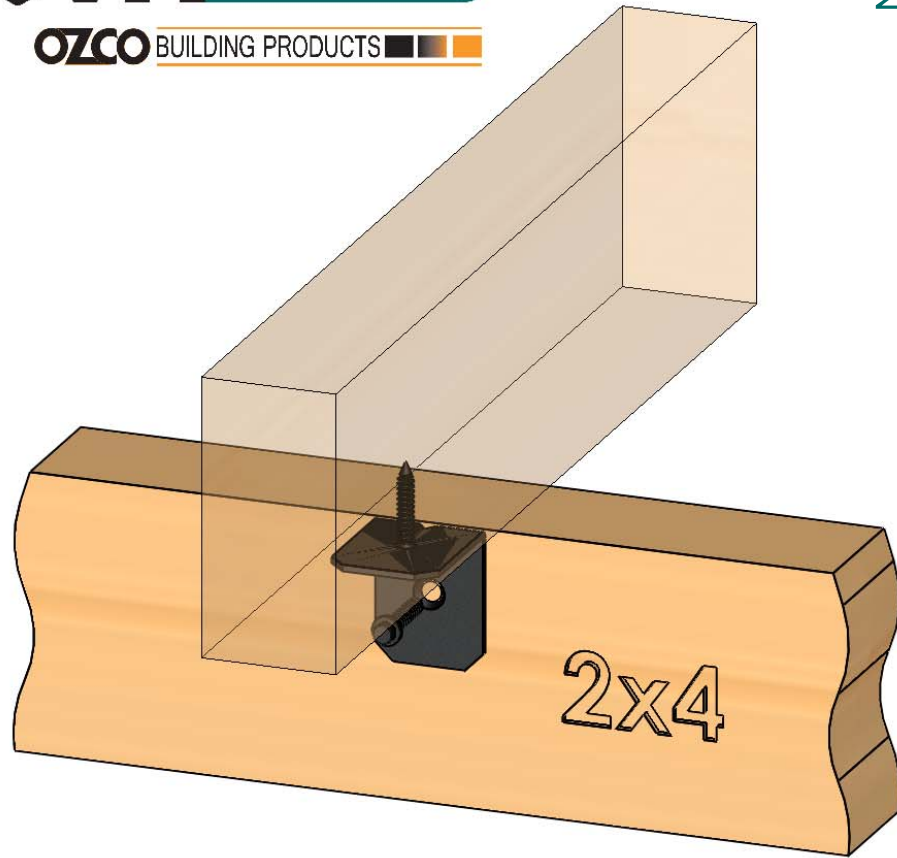

Scale: 1:2.5
Last updated: 12/14/2017

51717



OZCO BUILDING PRODUCTS

Product & Packaging Specs

51717 Packing

Item #: Box packing

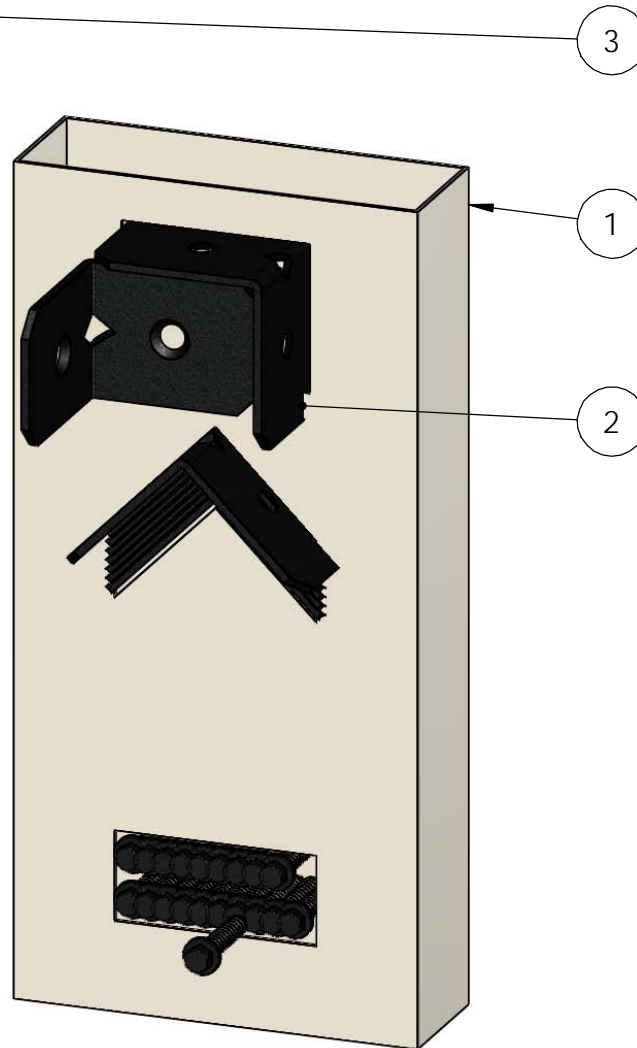

ITEM NO.	QTY.	PART NUMBER	DESCRIPTION
1	1	56617 Box Insert	Insert, 56617
2	10	51717-11	Clip, 2" Rafter
3	1	Box, 51717	Box, 51717
4	20	80060	Screw, 1- 1/2"x1/4" Black Hex- Head (1-1/2- HX-SCR)

screws shall be placed in plastic bag and packed as shown

Weight: 1.43 LBS

Scale: 1:2

Last updated: 12/14/2017

51717

Product & Packaging Specs

51717 Packing

Item #: Case packing

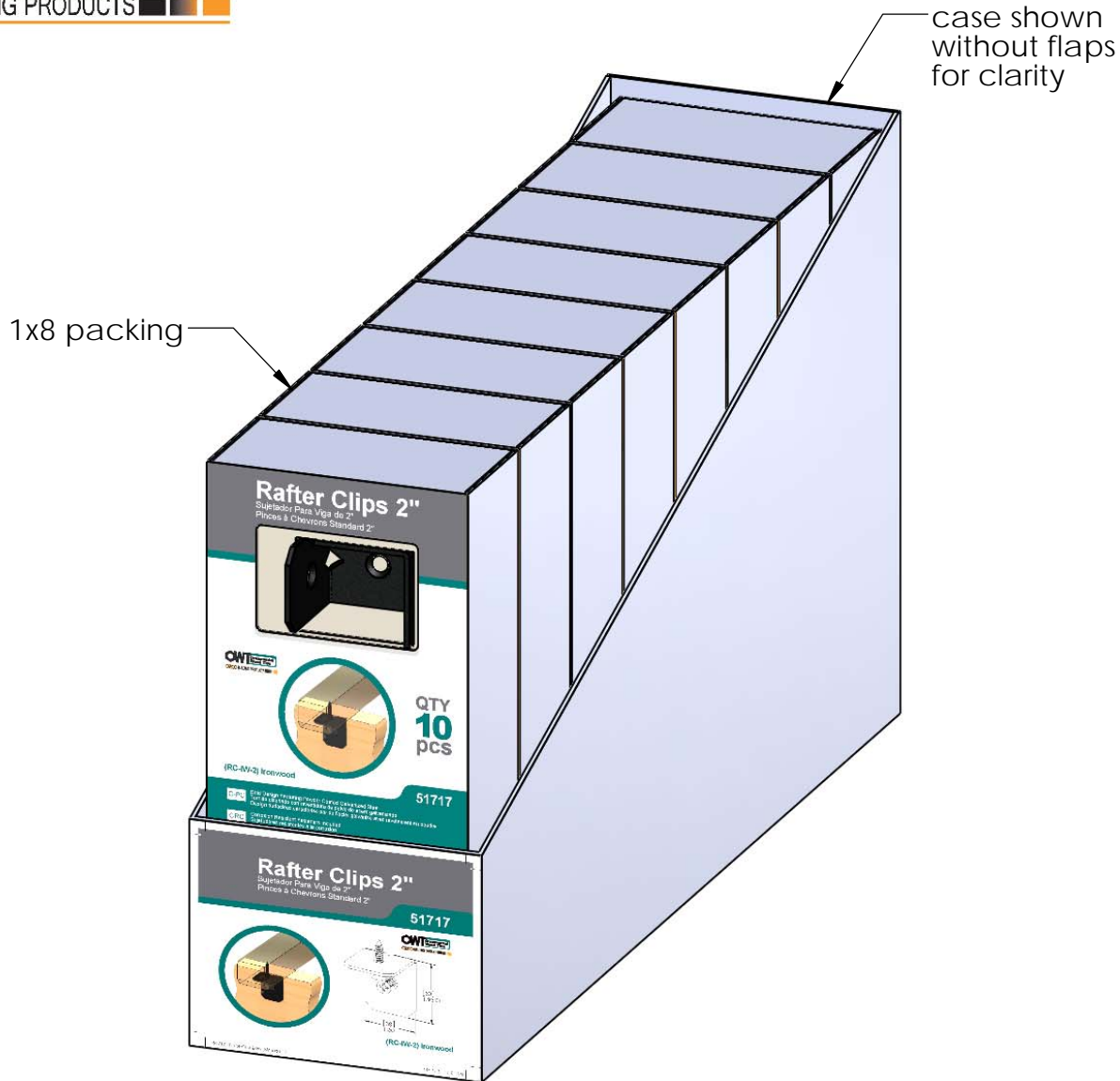

Weight: 16.64 LBS
 Scale: 1:3
 Last updated: 12/14/2017

51717

ADD PALLET LABEL

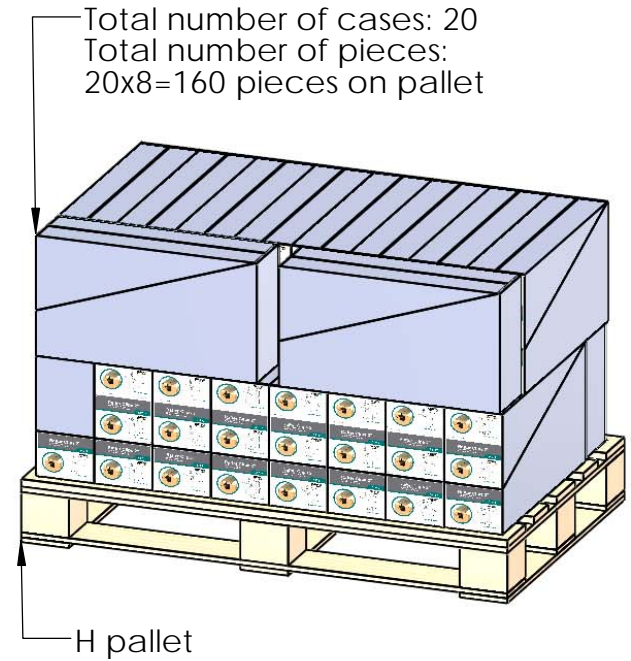
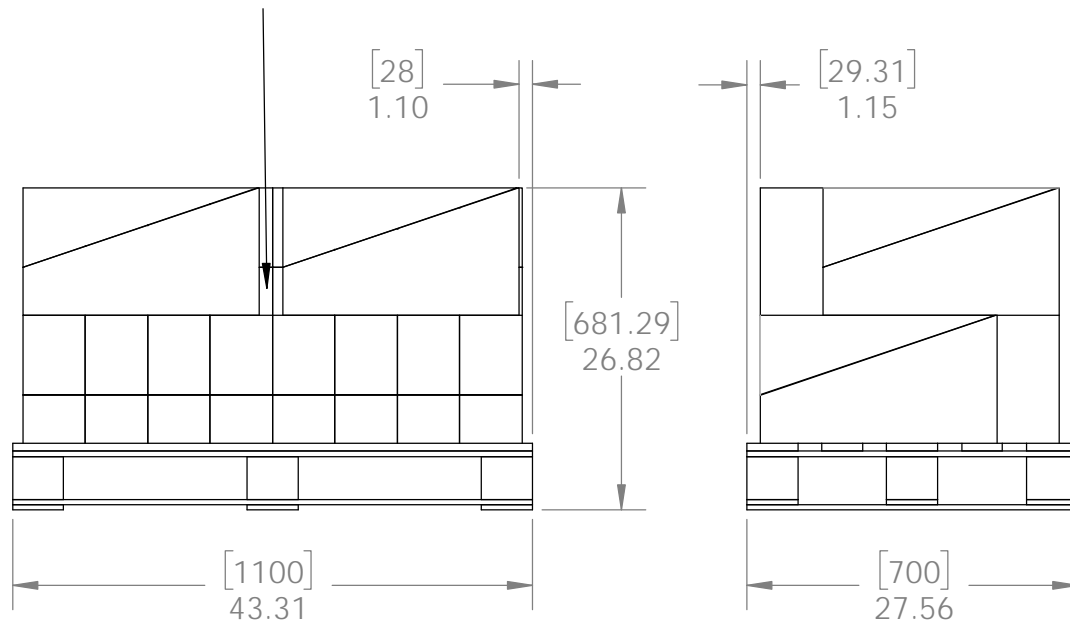

additional pallet packing instructions

- plywood on top layer
- strap to pallet
- clear wrap around boxes

Weight: 384 LBS
 Scale: 1:16
 Last updated: 12/14/2017

51717



OZCO BUILDING PRODUCTS

Product & Packaging Specs

41717 Packing

Item #: Box packing

Ironwood 2" Rafter Clips (2-Pack)
(RC-2-IW-2PK)
41717

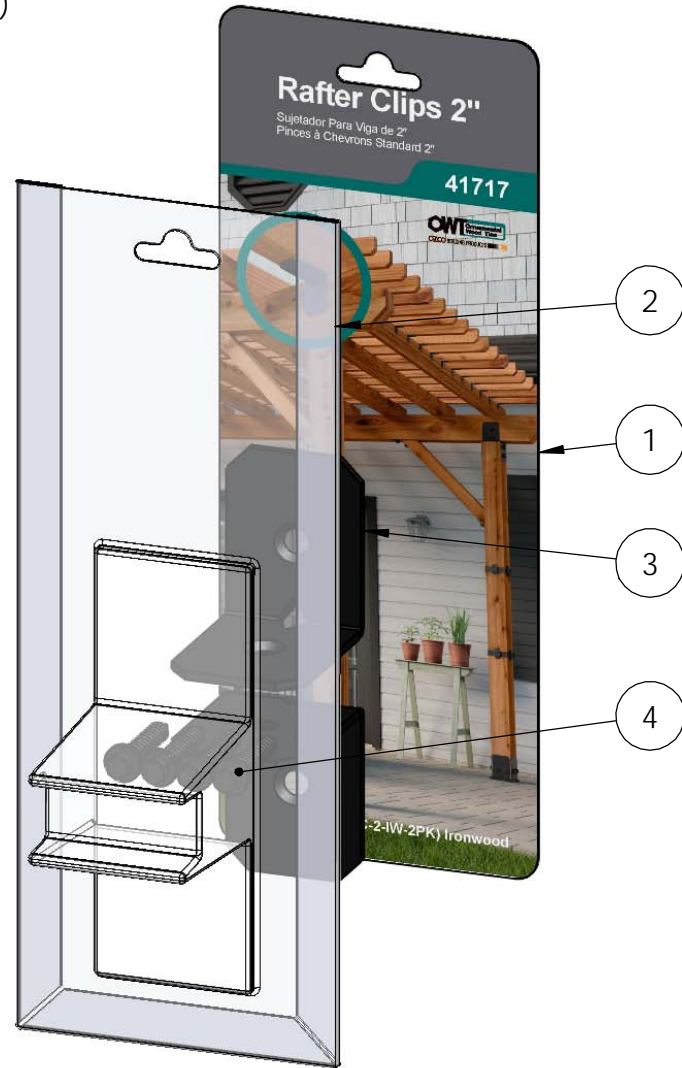

ITEM NO.	Box packing/ QTY.	PART NUMBER	DESCRIPTION
1	1	Box, 41717	Box, 41717
2	1	Box, 41717	Box, 41717
3	2	51717-11	Clip, 2" Rafter
4	4	80060	Screw, 1-1/2"x1/4" Black Hex-Head (1-1/2-HX-SCR)

screws placed in bag (not shown)

Material:
Finish:
Weight: 0.31 LBS
Scale: 1:4
Last updated: 12/14/2017

51717



OZCO BUILDING PRODUCTS

Product & Packaging Specs

41717 Packing

Item #: Case packing

Ironwood 2" Rafter Clips (2-Pack)
(RC-2-IW-2PK)
41817



Material:
Finish:
Weight: 6 LBS
Scale: 1:2.5
Last updated: 12/14/2017

51717



OZCO BUILDING PRODUCTS

Product & Packaging Specs

41717 Packing

Item #: Pallet packing

Ironwood 2" Rafter Clips (2-Pack)
(RC-2-IW-2PK)
41917

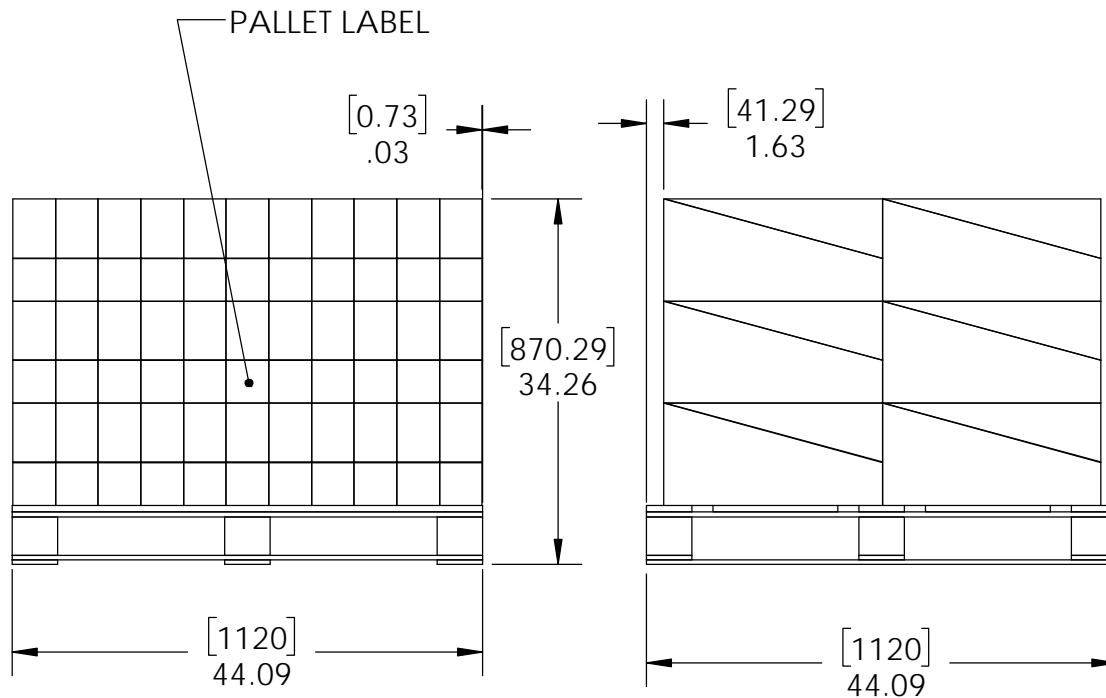

Total number of cases: 66
 Total number of pieces:
 $66 \times 17 = 1122$ pieces on pallet

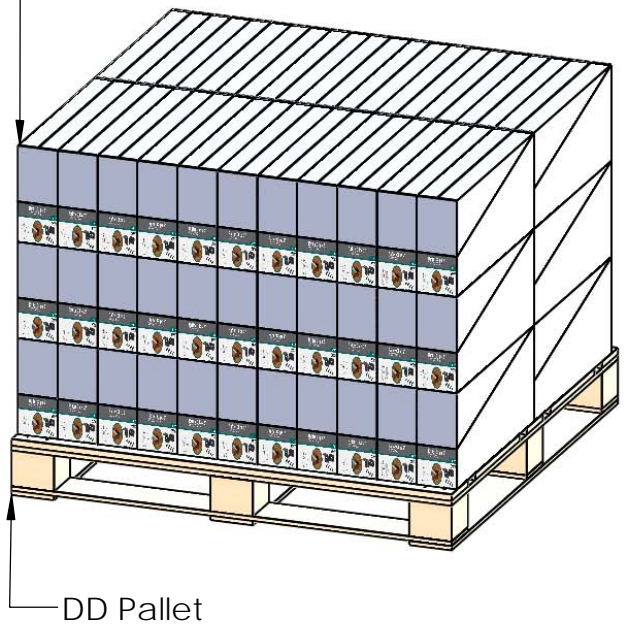

Material:
 Finish:
 Weight: 426 LBS
 Scale: 1:18
 Last updated: 12/14/2017

- additional pallet packing instructions
- plywood on top layer
 - strap to pallet
 - clear wrap around boxes



51717