

Product & Packaging Specs

2" Standard Rafter Clip (RC-LS-2)

Item #: 56617

ITEM NO.	QTY.	PART NUMBER	DESCRIPTION
1	1	56617-11	Clip, 2" Rafter
2	2	80060	Screw, 1-1/2"x1/4" Black Hex-Head (1-1/2-HX-SCR)

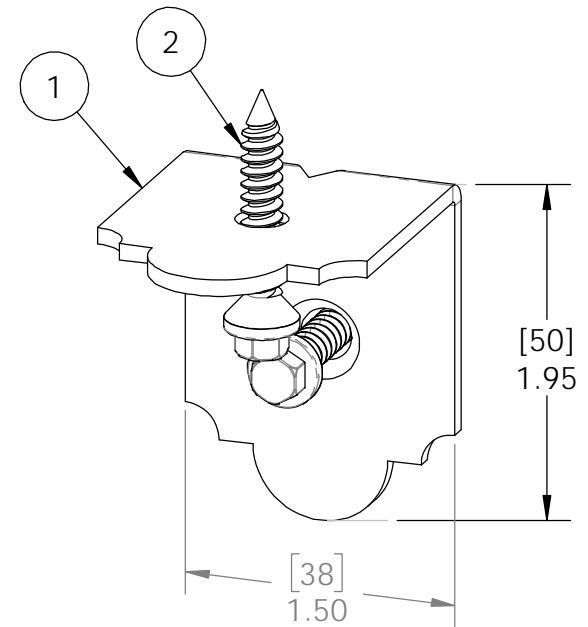
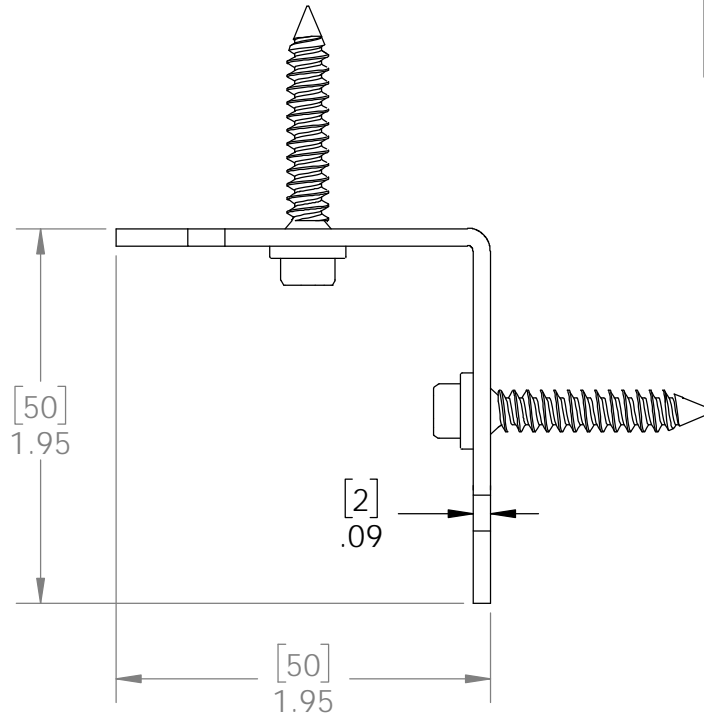
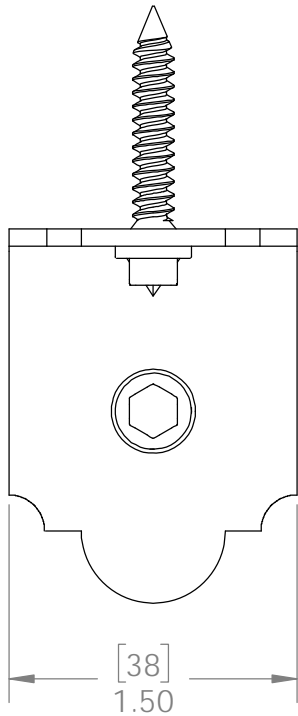

Weight: 0.12 LBS
 Scale: 1:1
 Last updated: 12/14/2017

56617-10



OZCO BUILDING PRODUCTS

Product & Packaging Specs

2" Standard Rafter Clip (RC-LS-2)

Item #: 56617

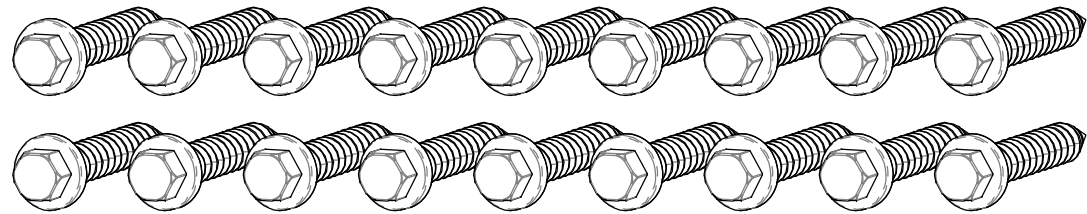
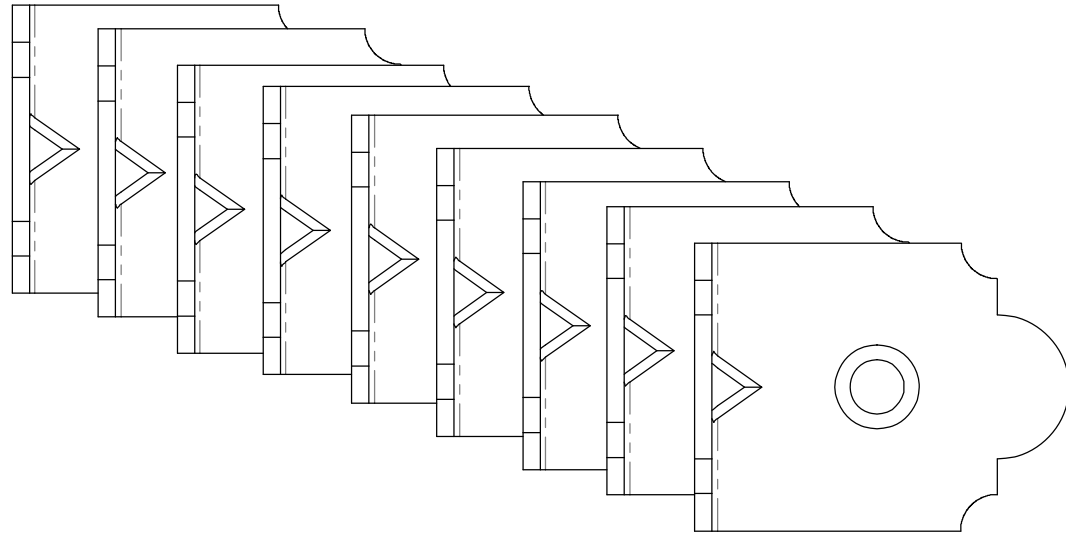
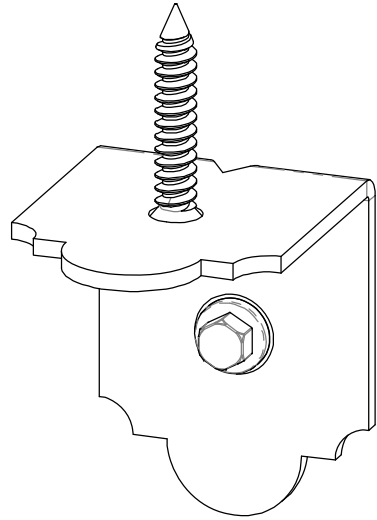

Weight: 0.12 LBS
Scale: 1:1
Last updated: 12/14/2017

56617-10



Product & Packaging Specs

2" Standard Rafter Clip (RC-LS-2)

Item #: Typical Installation & Basic Assembly

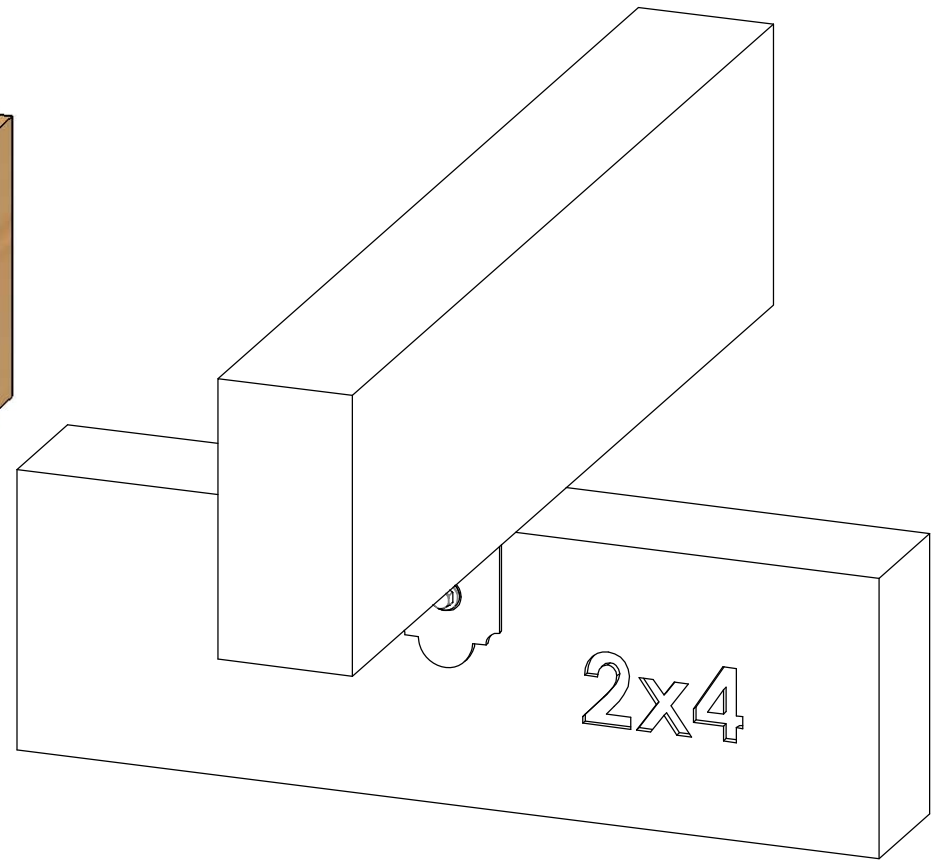
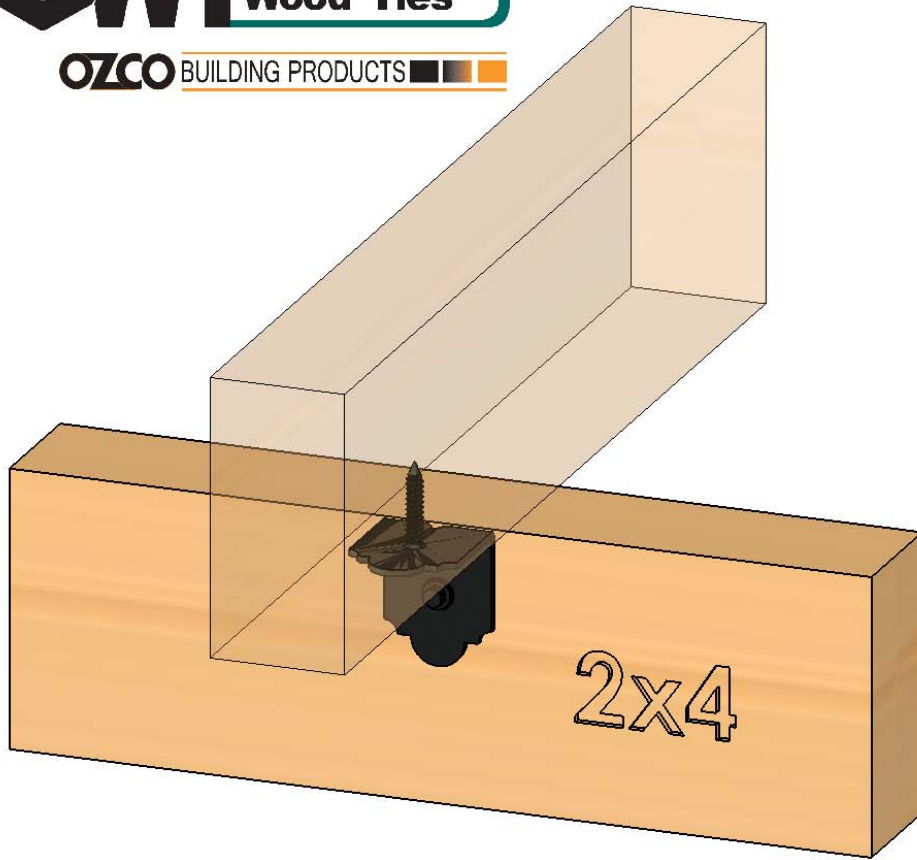

Weight: 0.12 LBS
Scale: 1:2.5
Last updated: 12/14/2017

56617-10

V2.00 - Installation Instructions, Specifications and Project Plans are effective 12/14/2017. This information is updated periodically, and should not be relied upon after 2 years from 12/14/2017. Please visit OZCOBP.com to get current information.

Product & Packaging Specs

2" Standard Rafter Clip (RC-LS-2)

Item #: Typical Installation & Basic Assembly

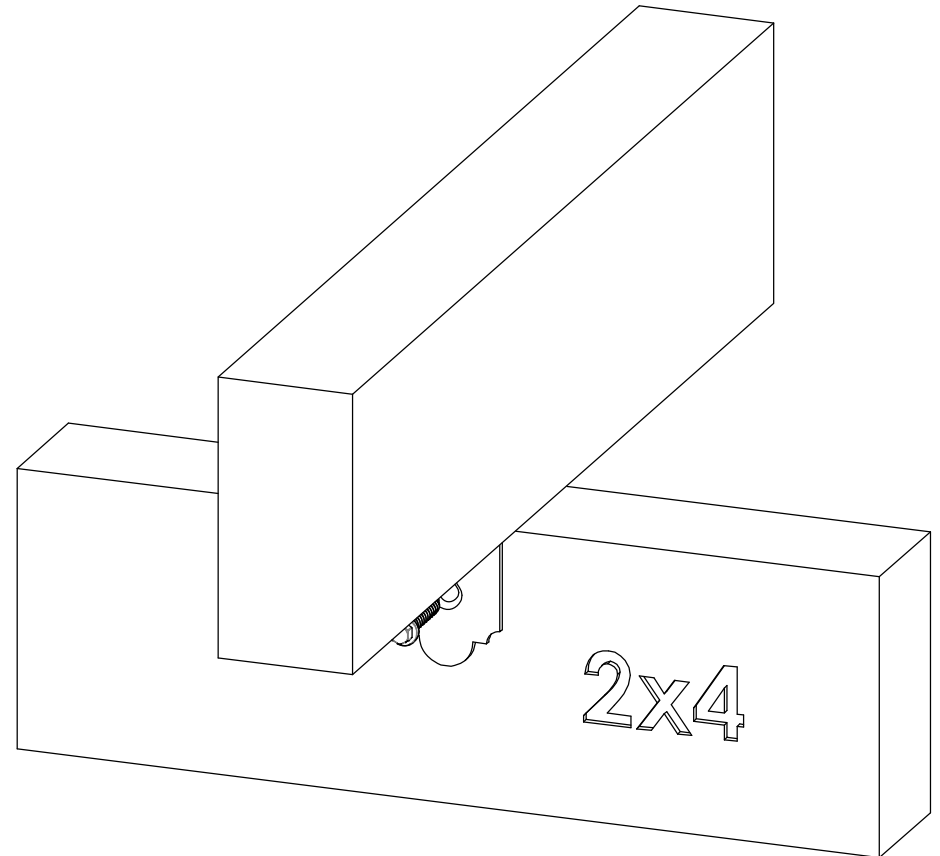
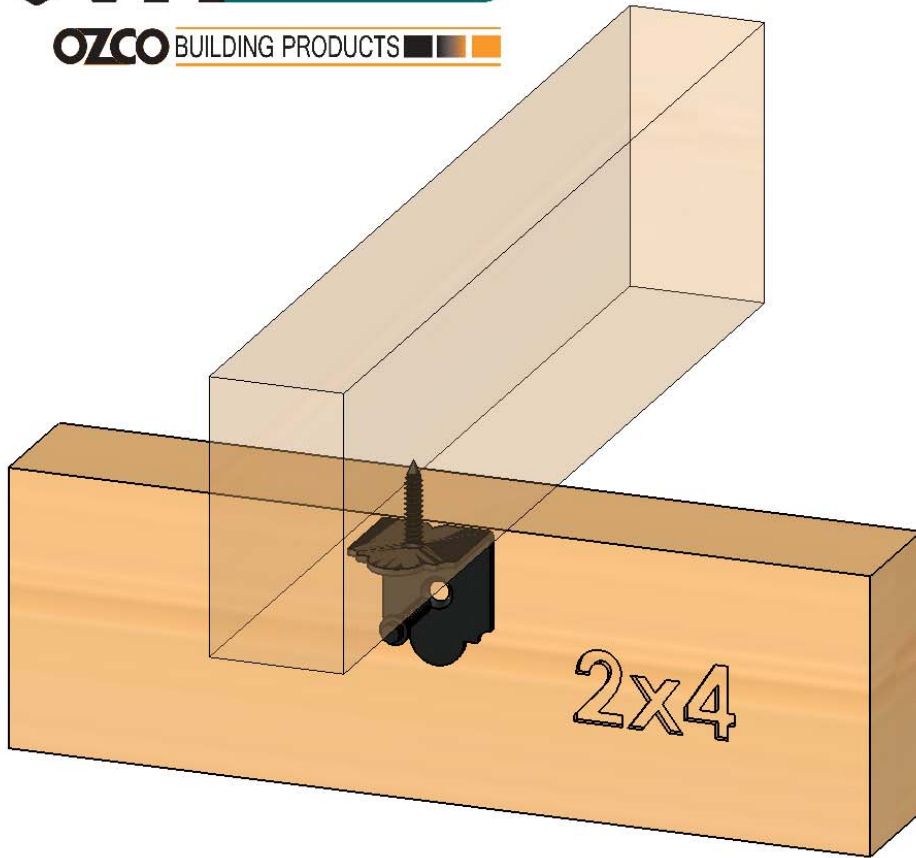

Weight: 0.12 LBS
Scale: 1:2.5
Last updated: 12/14/2017

56617-10



OZCO BUILDING PRODUCTS

Product & Packaging Specs

56617 Packing

Item #: Box packing

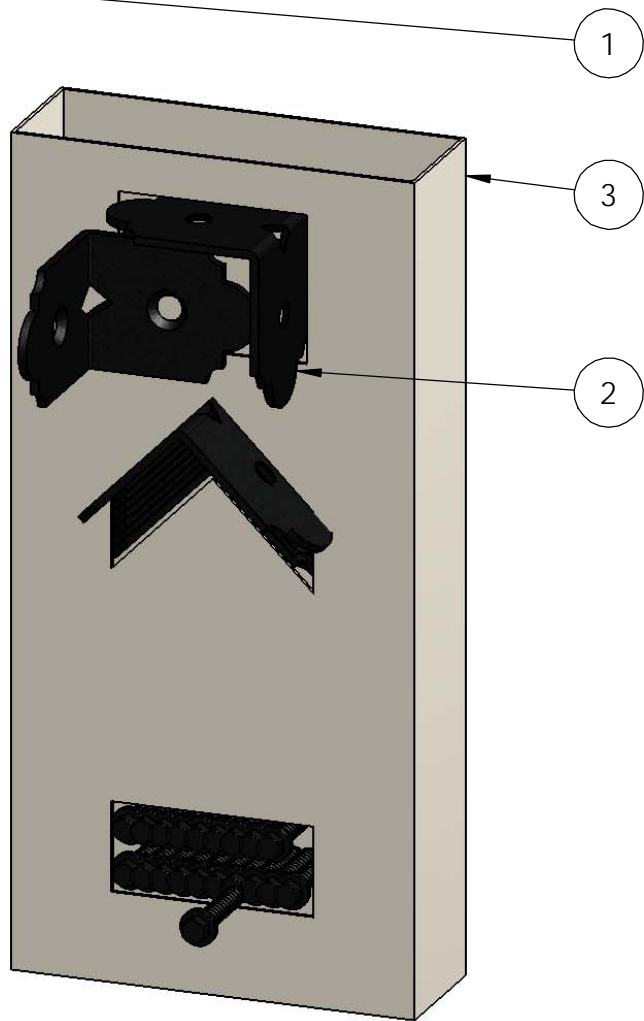

ITEM NO.	QTY.	PART NUMBER	DESCRIPTION
1	1	Box, 56617	Box, 56617
2	10	56617-11	Clip, 2" Rafter
3	1	56617 Box Insert	Insert, 56617
4	20	80060	Screw, 1-1/2"x1/4" Black Hex-Head (1-1/2-HX-SCR)

screws shall be placed in plastic bag and packed as shown

Weight: 1.26 LBS
 Scale: 1:2
 Last updated: 12/14/2017

56617-10

Product & Packaging Specs

56617 Packing

Item #: Case packing

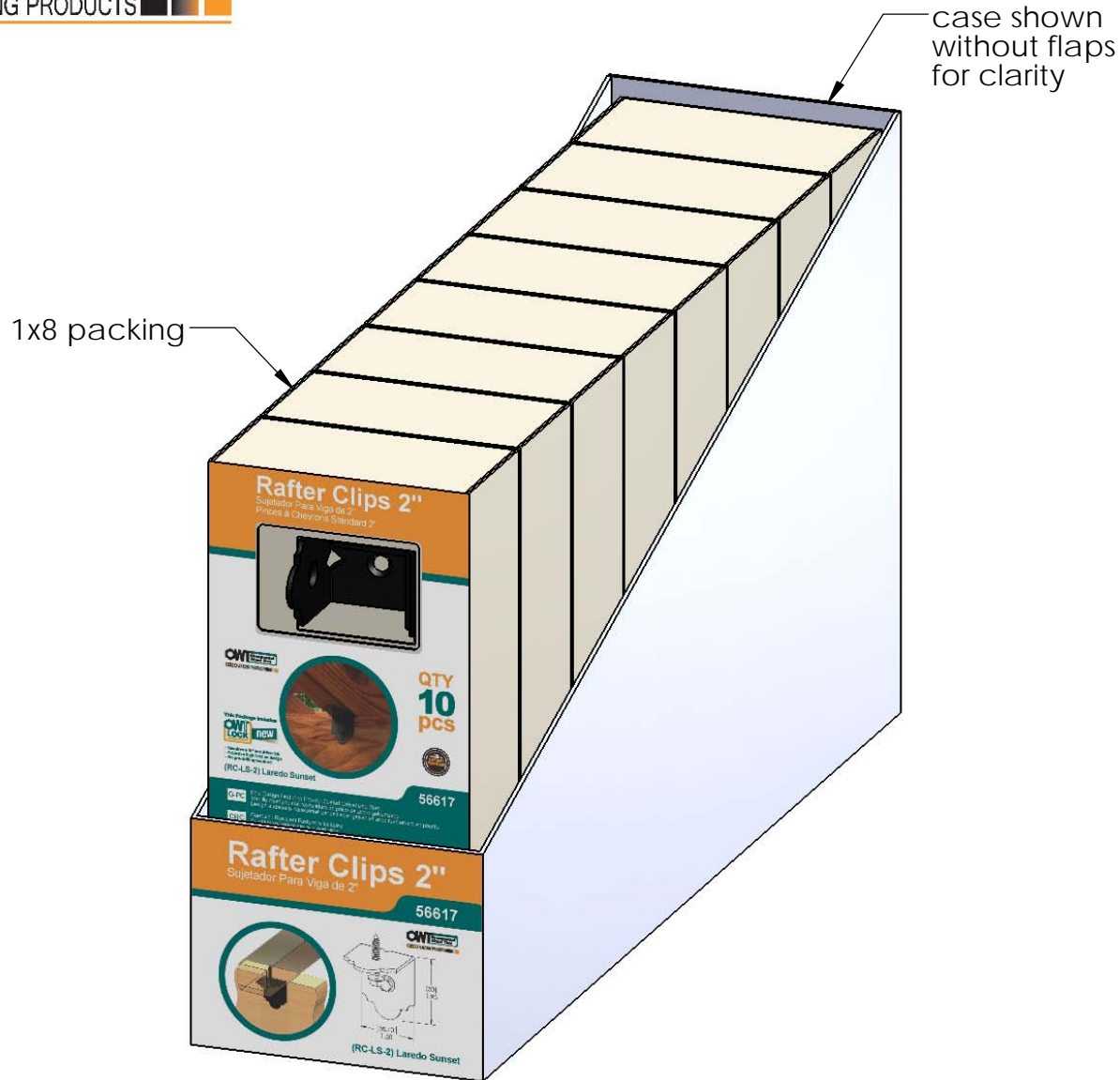

Weight: 16.64 LBS
 Scale: 1:3
 Last updated: 12/14/2017

56617-10

Item #: **56617** | **RC-LS-2**
 2" Rafter Clips LS
PALLET 160 pcs
 sku#: **56817**
 Weight: 384 lbs
 LOT# _____ Priority# _____

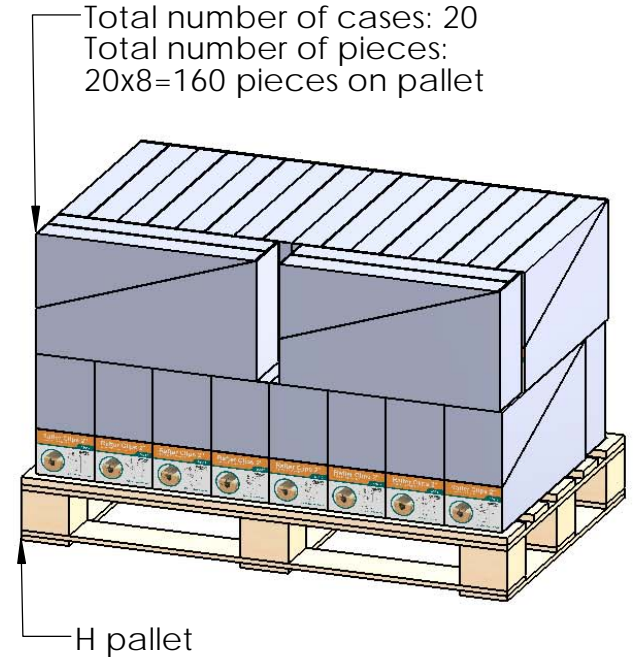
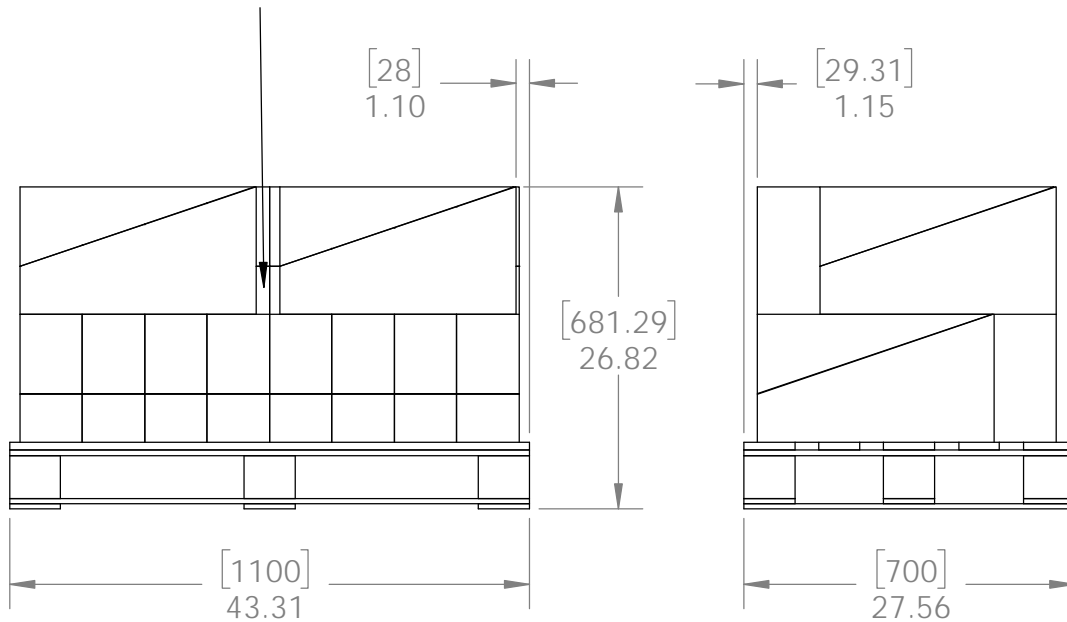

additional pallet packing instructions

- plywood on top layer
- strap to pallet
- clear wrap around boxes

Weight: 384 LBS
 Scale: 1:16
 Last updated: 12/14/2017

56617-10



OZCO BUILDING PRODUCTS

Product & Packaging Specs

Box, 46617

Item #: Backing

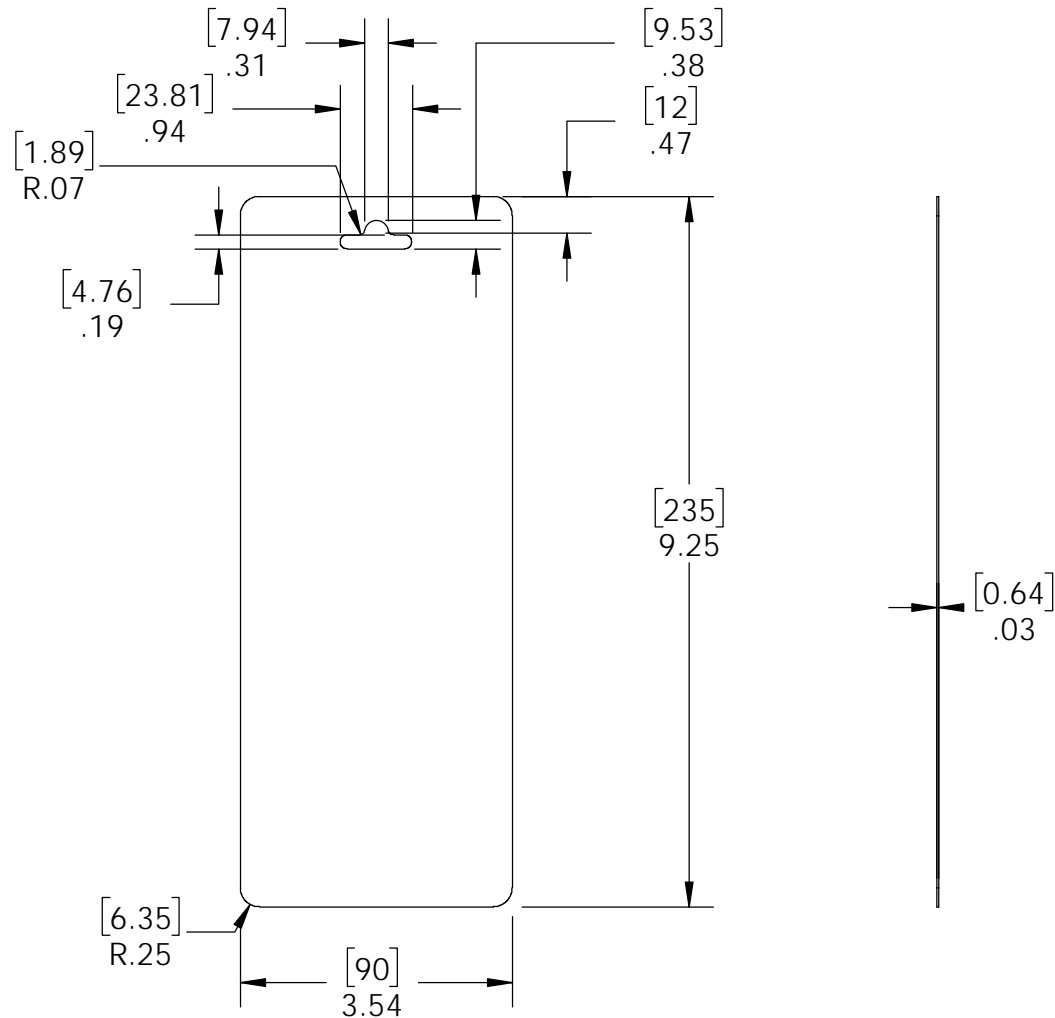

Material: Corrugated Paper
 Finish: See Artwork
 Weight: 2.08 LBS
 Scale: 1:2
 Last updated: 12/14/2017

56617-10

V2.00 - Installation Instructions, Specifications and Project Plans are effective 12/14/2017 . This information is updated periodically and should not be relied upon after 2 years from 12/14/2017 . Please visit OZCOBP.com to get current information.



OZCO BUILDING PRODUCTS

Product & Packaging Specs

41717 Packing

Item #: Box packing

Laredo Sunset 2" Rafter Clips
(2-Pack) (RC-2-LS-2PK)
46617

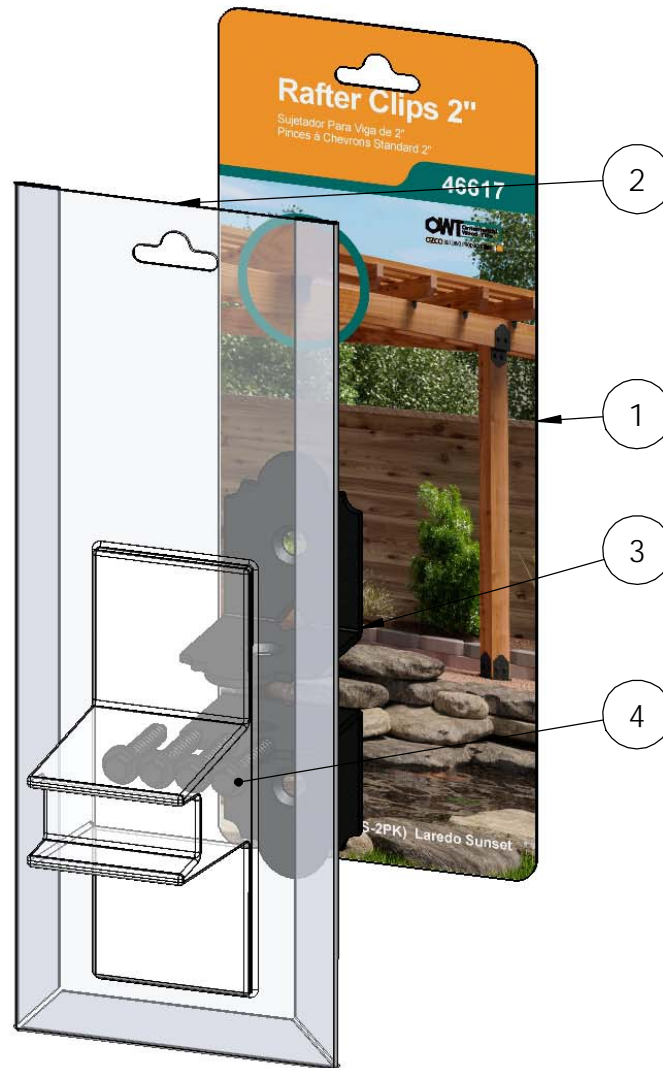

ITEM NO.	Box packing/ QTY.	PART NUMBER	DESCRIPTION
1	1	Box, 46617	Box, 46617
2	1	Box, 46617	Box, 46617
3	2	56617-11	Clip, 2" Rafter
4	4	80060	Screw, 1-1/2"x1/4" Black Hex-Head (1-1/2-HX-SCR)

screws placed in bag (not shown)

Material:
Finish:
Weight: 0.27 LBS
Scale: 1:4
Last updated: 12/14/2017

56617-10



OZCO BUILDING PRODUCTS

Product & Packaging Specs

46617 Packing

Item #: Case packing

Laredo Sunset 2" Rafter Clips (2-Pack) (RC-2-LS-2PK) 46717



Material:
Finish:
Weight: 6 LBS
Scale: 1:16
Last updated: 12/14/2017

56617-10

V2.00 - Installation Instructions, Specifications and Project Plans are effective 12/14/2017 . This information is updated periodically and should not be relied upon after 2 years from 12/14/2017 . Please visit OZCOBP.com to get current information.



OZCO BUILDING PRODUCTS

Product & Packaging Specs

41717 Packing

Item #: Pallet packing

Laredo Sunset 2" Rafter
Clips (2-Pack) (RC-2-LS-2PK)
46817

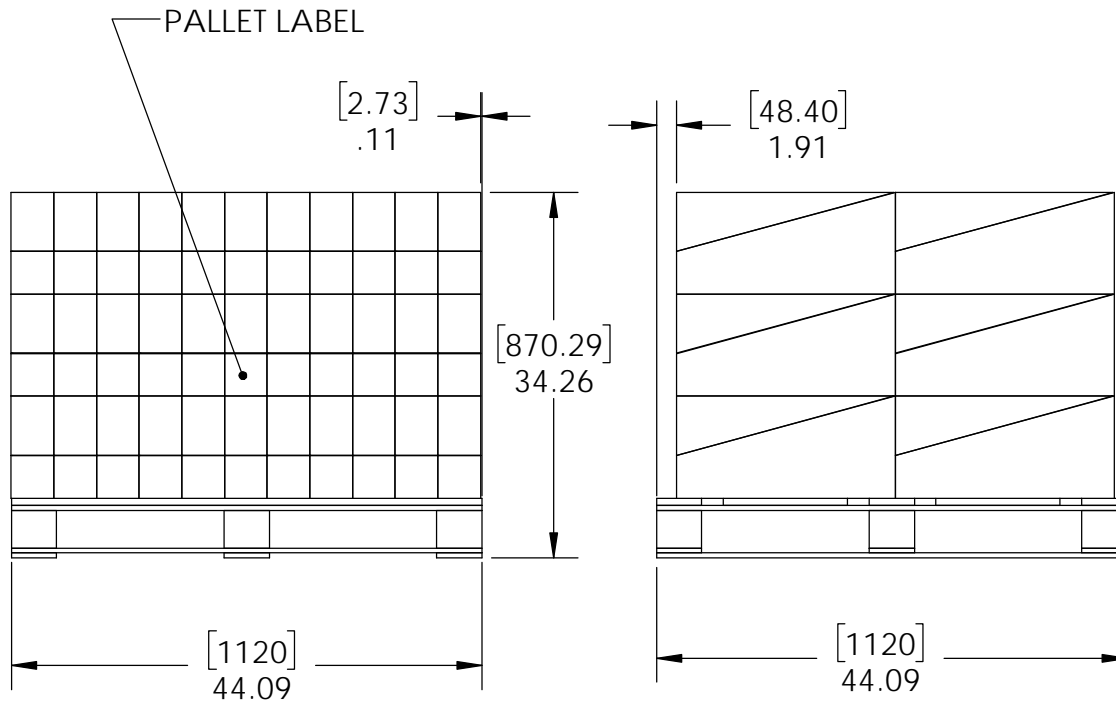

Total number of cases: 66

Total number of pieces:
 $66 \times 17 = 1122$ pieces on pallet

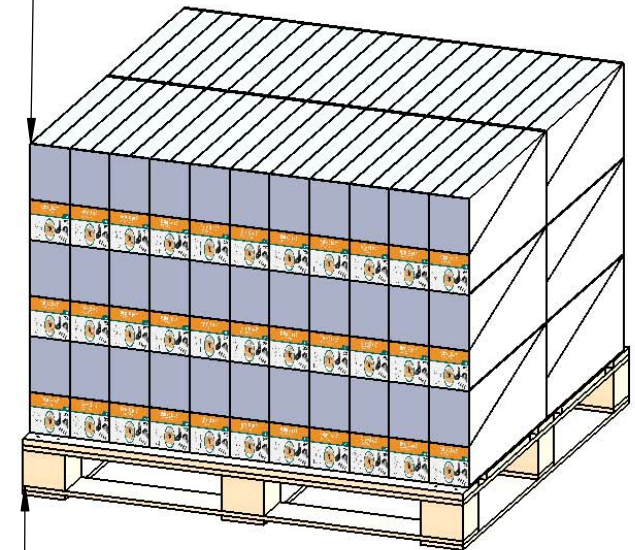

DD Pallet

Material:
Finish:
Weight: 426 LBS
Scale: 1:18
Last updated: 12/14/2017

- additional pallet packing instructions
- plywood on top layer
 - strap to pallet
 - clear wrap around boxes



56617-10