

# Product & Packaging Specs

## 2x4 Top Rail Saddle (2x4-TR)

Item #: 56641

for use with nominal 2x4 (1-1/2" x 3-1/2")

ITEM NO.	QTY.	PART NUMBER	DESCRIPTION
1	6	80016	#12 x 1-1/4 Torx HD Sharp Point (T25)
2	1	56641-12	Bracket, 2x4 Top Rail Saddle

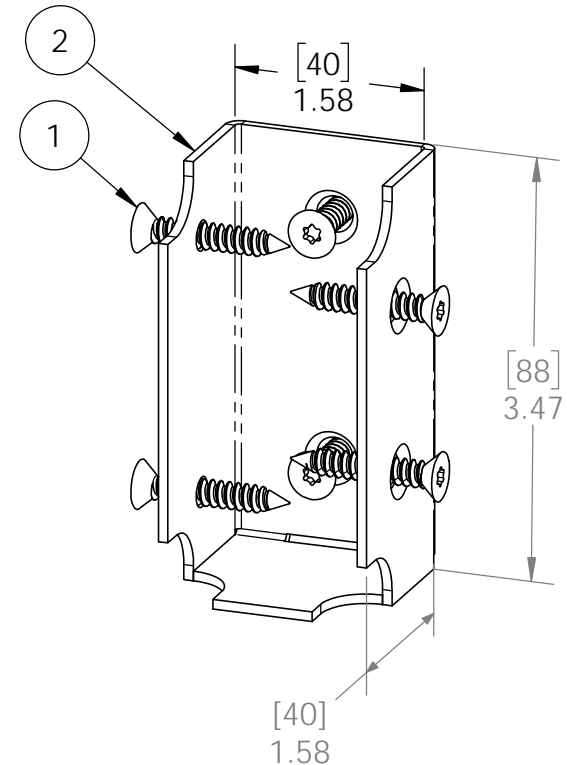
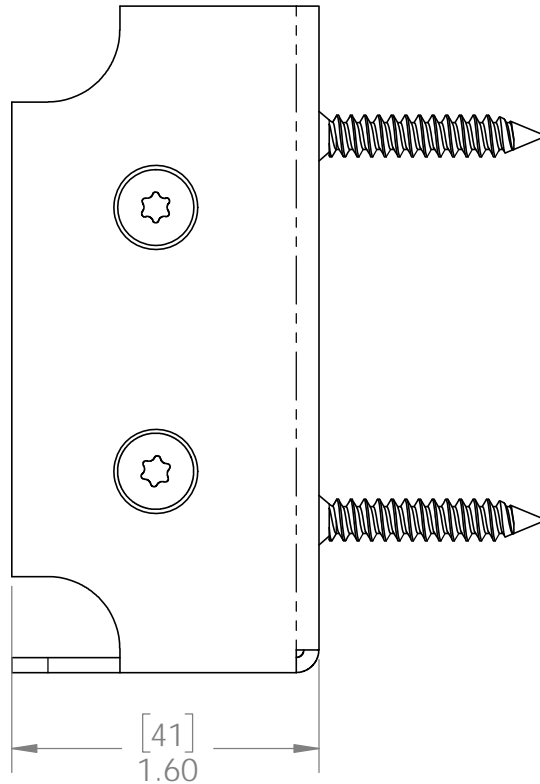
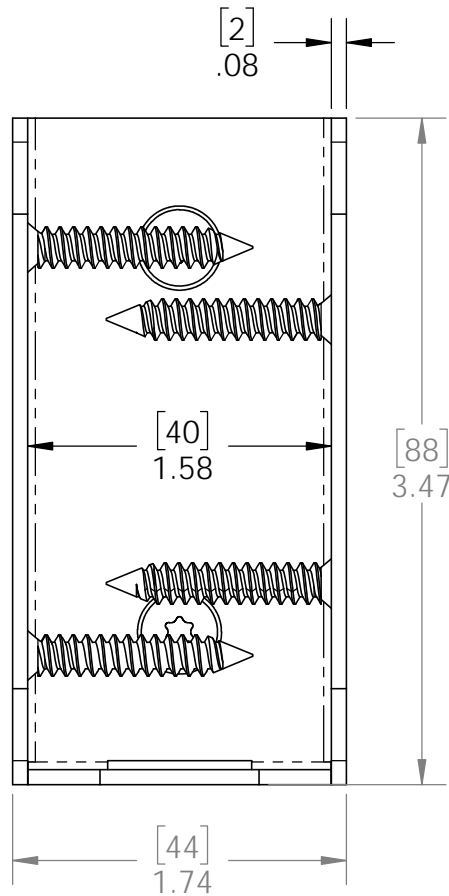

Weight: 0.43 LBS  
 Scale: 1:1  
 Last updated: 12/23/2016

56641-10

revision B adds bend relief  
 revision C corrects #10 screws to #12

V2.00 - Installation Instructions, Specifications and Project Plans are effective 12/23/2016. This information is updated periodically and should not be relied upon after 2 years from 12/23/2016. Please visit OZCOBP.com to get current information.

# Product & Packaging Specs

## 2x4 Top Rail Saddle (2x4-TR)

Item #: Typical Installation & Basic Assembly

for use with nominal 2x4 (1-1/2" x 3-1/2")

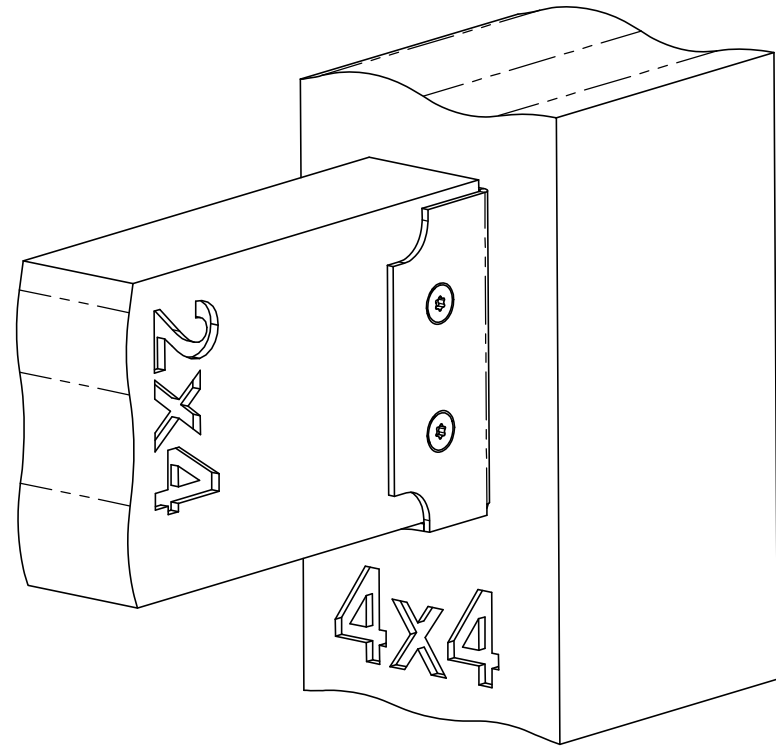
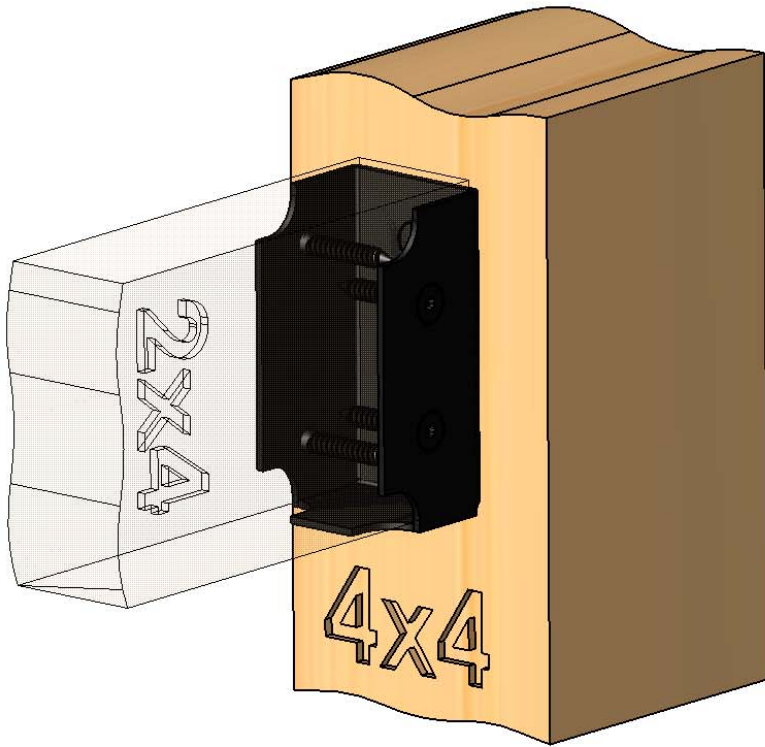

Weight: 0.43 LBS  
Scale: 1:2  
Last updated: 12/23/2016

56641-10

# Product & Packaging Specs

## 2x4 Top Rail Saddle (2x4-TR)

Item #: Typical Installation & Basic Assembly

for use with nominal 2x4 (1-1/2" x 3-1/2")

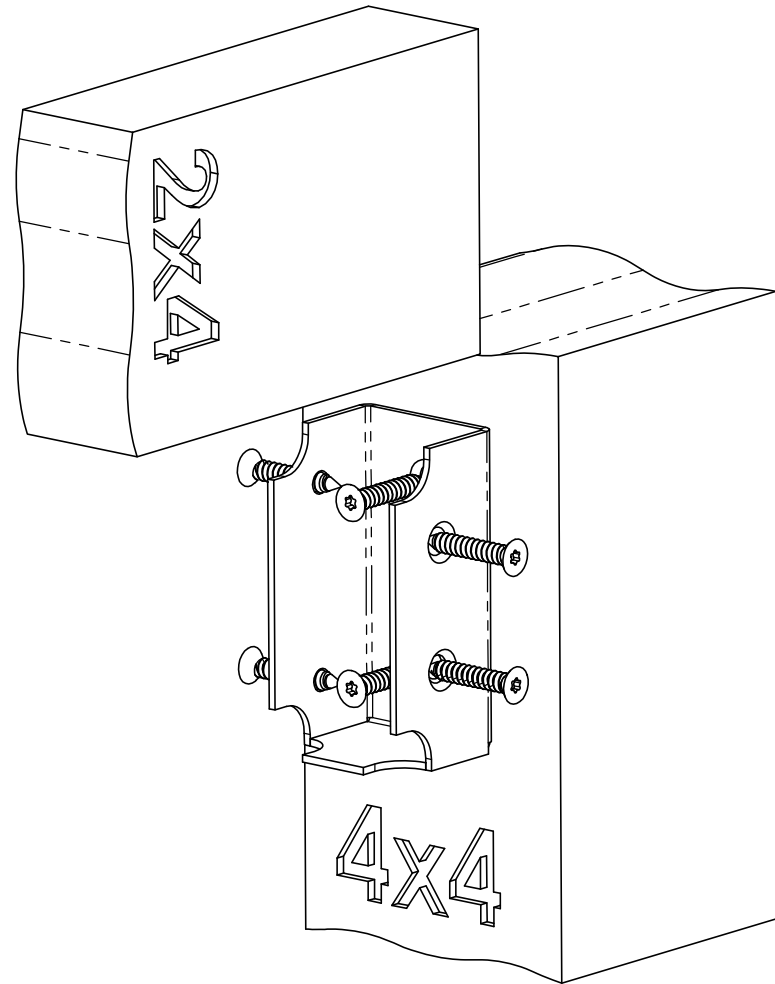
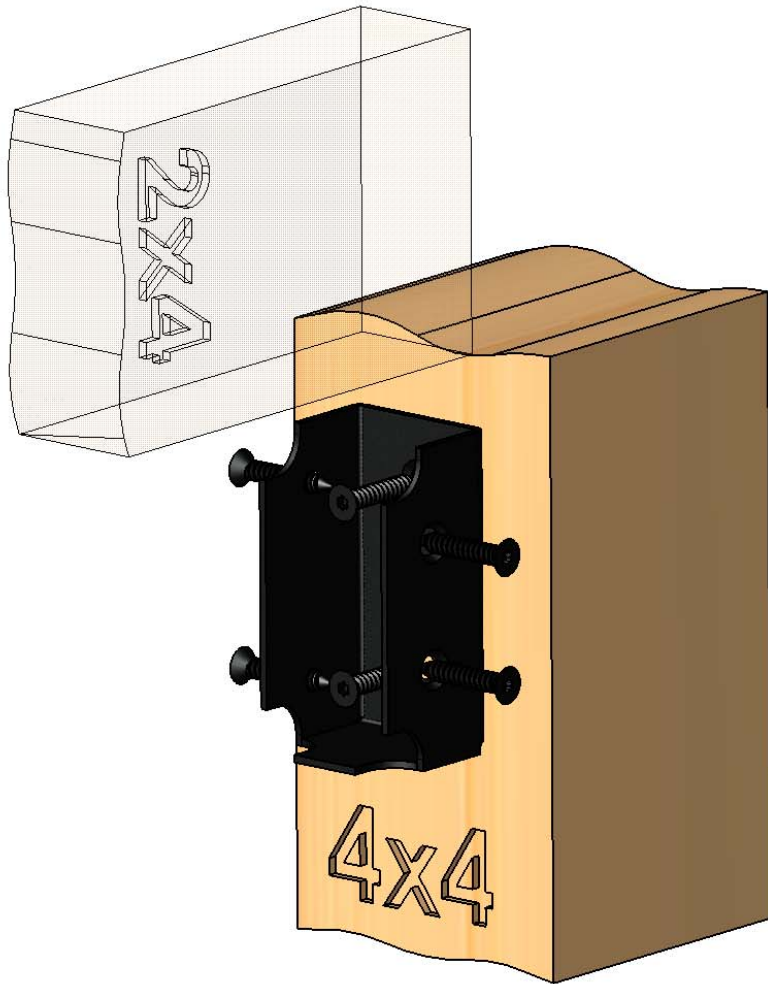

Weight: 0.43 LBS  
Scale: 1:2  
Last updated: 12/23/2016

56641-10

# Product & Packaging Specs

## 2x4 Top Rail Saddle (2x4-TR)

Item #: 56641

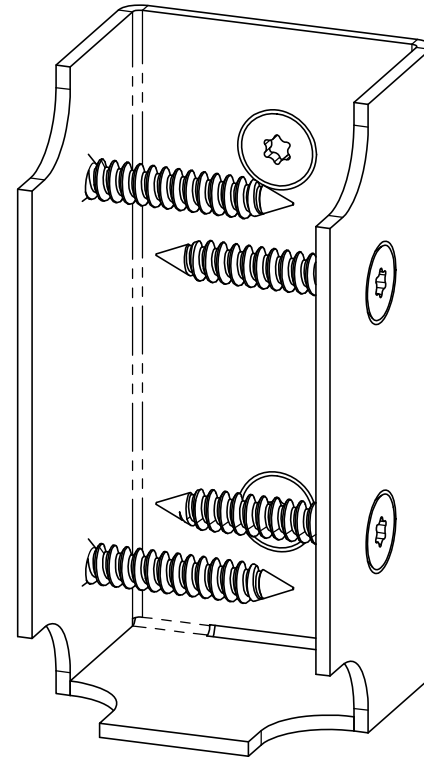
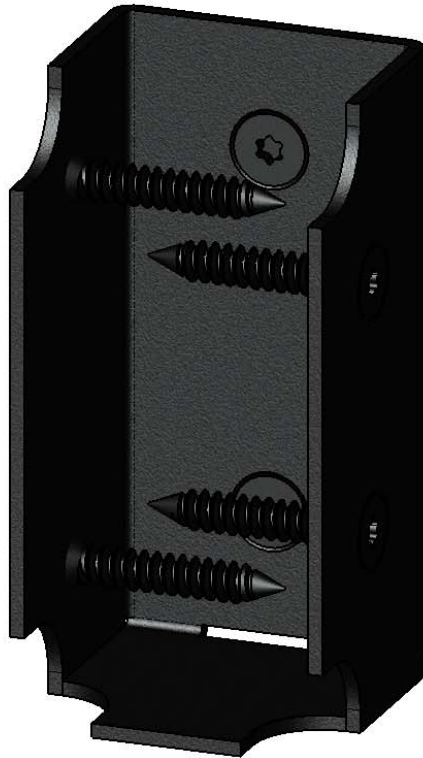

Weight: 0.43 LBS  
Scale: 1:1  
Last updated: 12/23/2016

for use with nominal 2x4 (1-1/2" x 3-1/2")

# Product & Packaging Specs

Box, 56641  
 Item #: Box

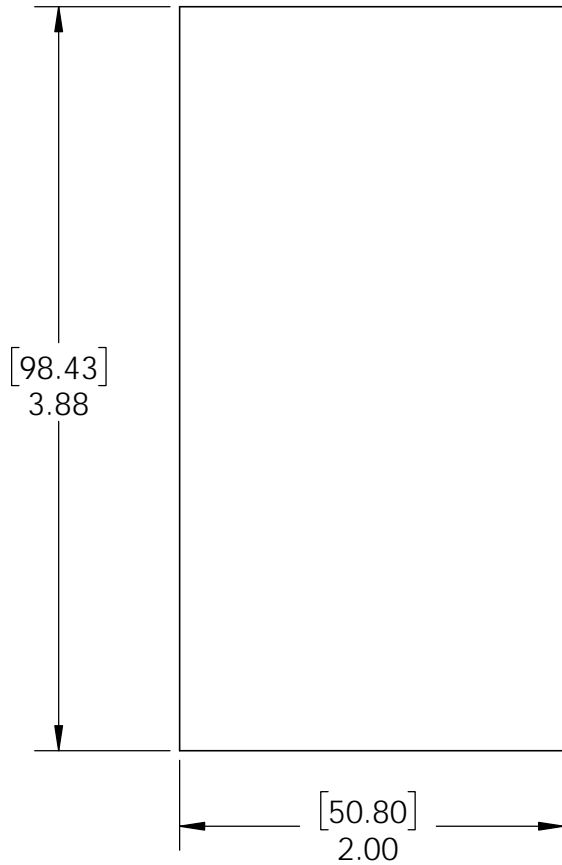

Material: Corrugated Paper  
 Finish: See Artwork  
 Weight: 0.01 LBS  
 Scale: 1:1  
 Last updated: 12/23/2016

56641-10



OZCO BUILDING PRODUCTS

# Product & Packaging Specs

56641 Packing

Item #: Box packing



ITEM NO.	QTY.	PART NUMBER	DESCRIPTION
1	1	Box, 56641	Box, 56641
2	1	56641	2x4 Top Rail Saddle (2x4-TR)

screws shall be placed in bag and placed between brackets

Weight: 0.86 LBS  
 Scale: 1:1.5  
 Last updated: 12/23/2016

56641-10

revision B adds bend relief  
 revision C corrects #10 screws to #12

V2.00 - Installation Instructions, Specifications and Project Plans are effective 12/23/2016. This information is updated periodically and should not be relied upon after 2 years from 12/23/2016. Please visit OZCOBP.com to get current information.

# Product & Packaging Specs

Case, 56641

Item #: Case

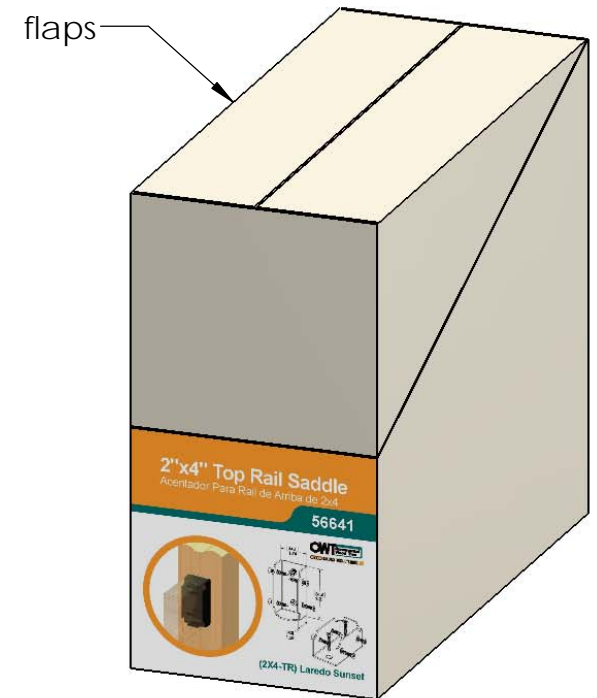
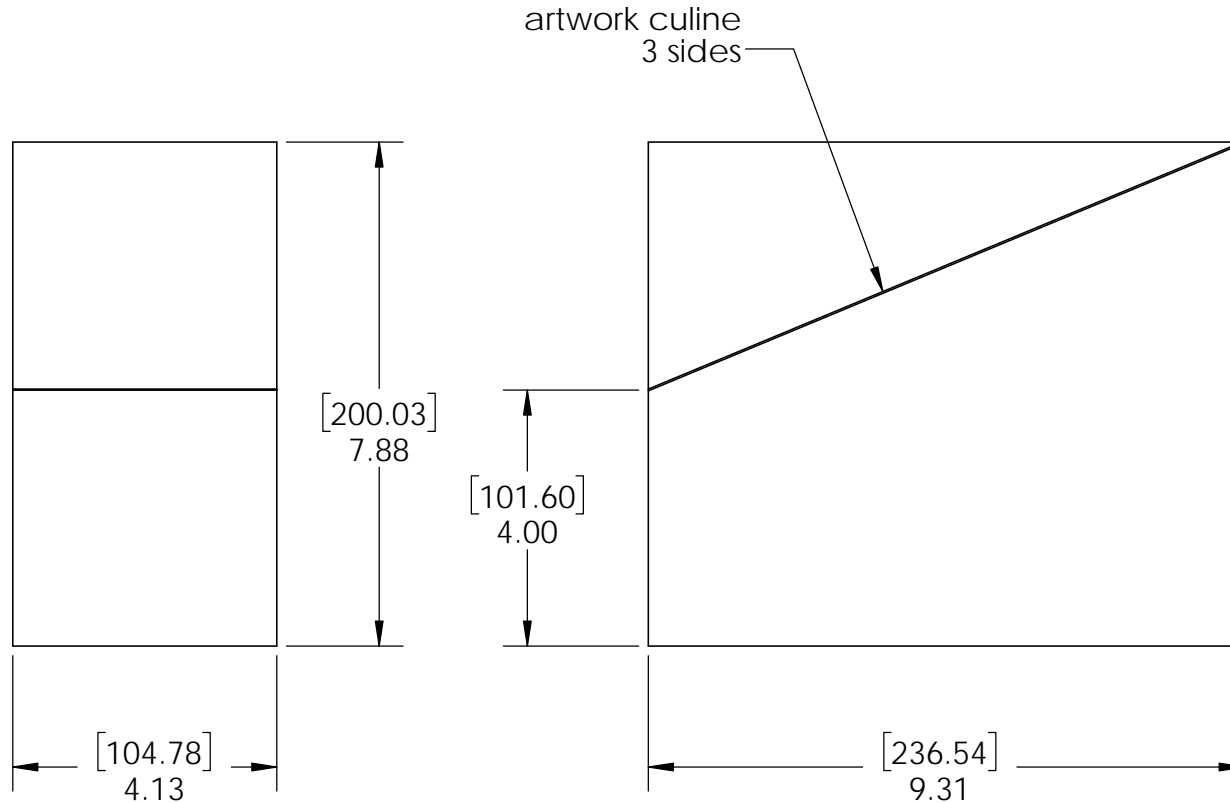

Material: Corrugated Paper  
 Finish: Natural  
 Weight: 0.06 LBS  
 Scale: 1:3  
 Last updated: 12/23/2016

56641-10

# Product & Packaging Specs

## 56641 Packing

Item #: Case packing

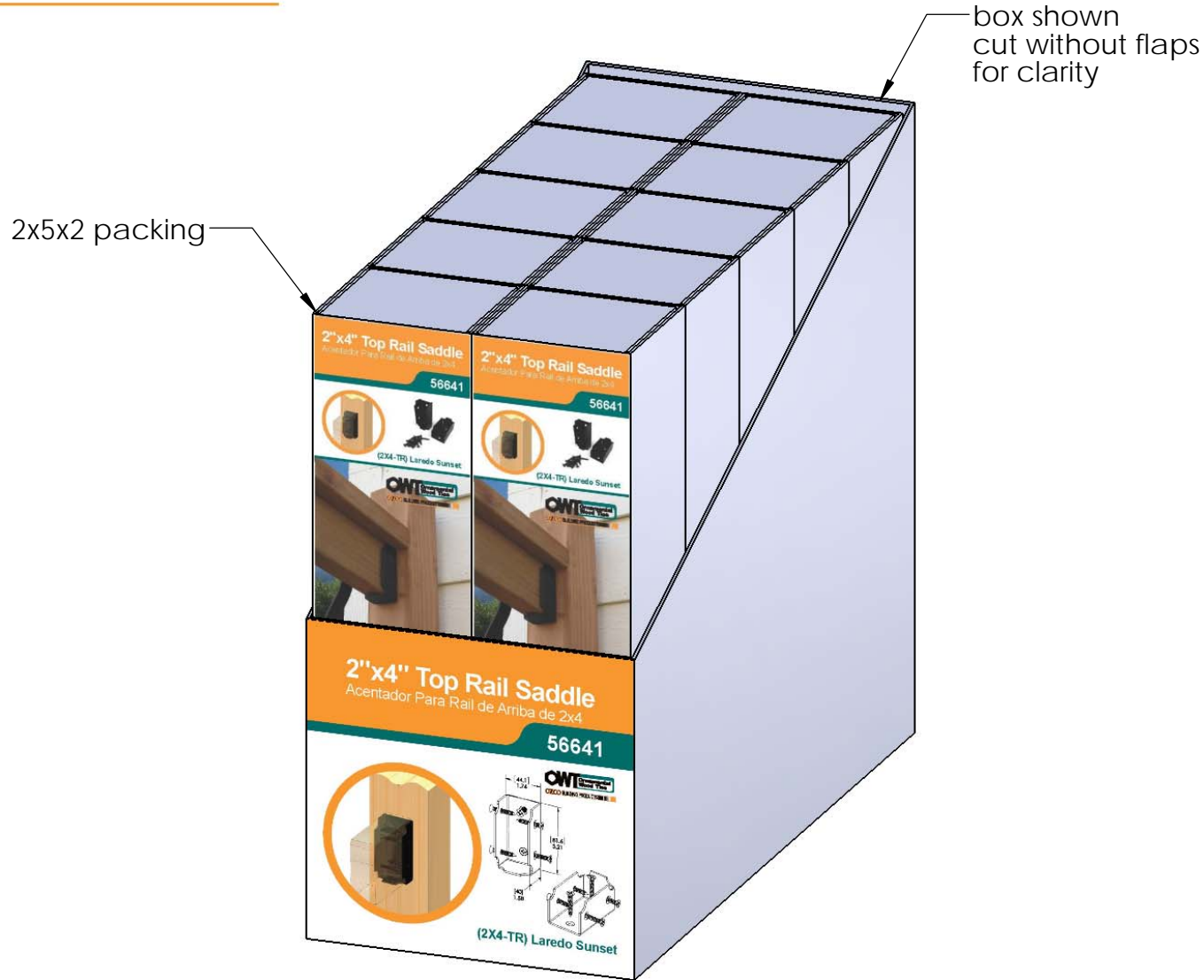

Weight: 9.17 LBS  
 Scale: 1:2  
 Last updated: 12/23/2016

56641-10





OZCO BUILDING PRODUCTS

# Product & Packaging Specs

56641 Packing

Item #: Case packing

Item #: **56641** | **2x4-TR**

2x4 Top Rail Saddle LS

**PALLET** **1500 pcs**

SKU#: **56841**



Weight: **1683** lbs

LOT#

Priority#

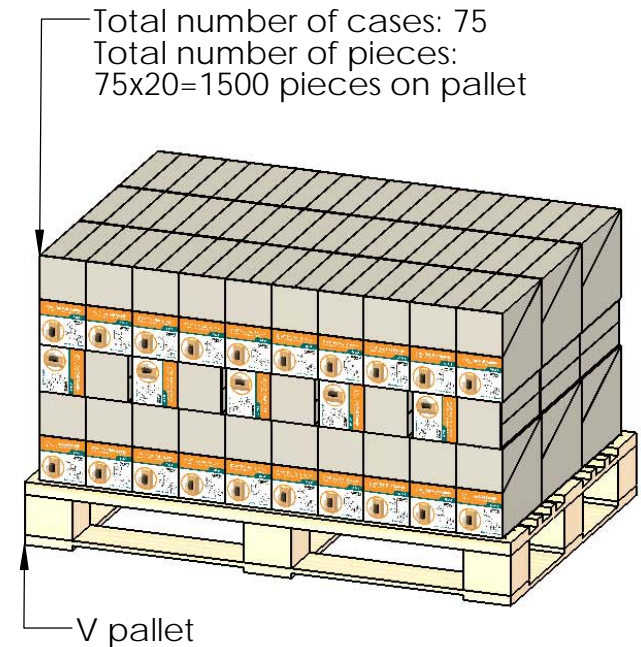
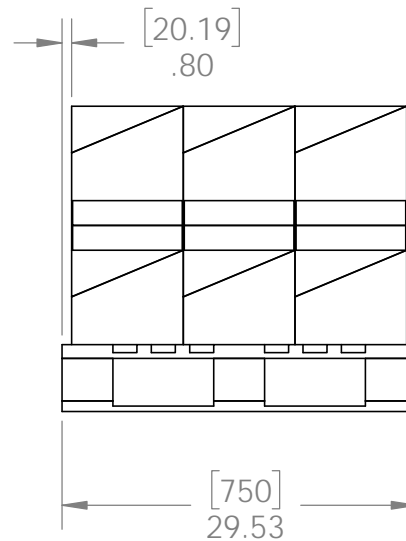
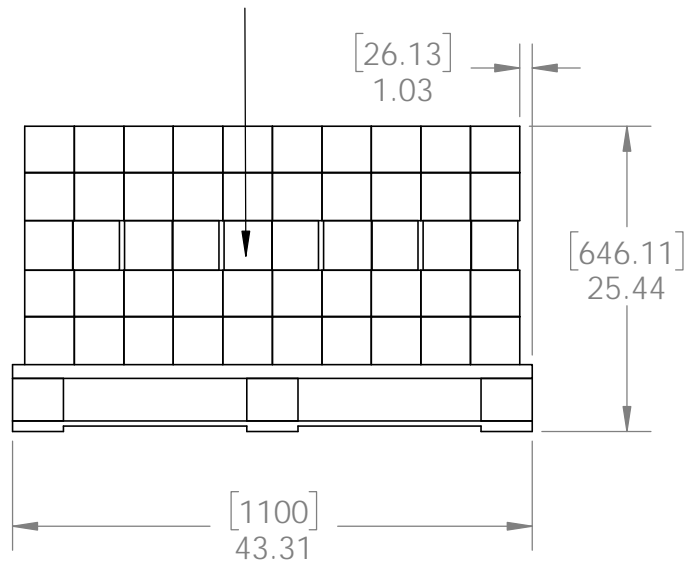

additional pallet packing instructions

- plywood on top layer
- strap to pallet
- clear wrap around boxes

Weight: 1638 LBS  
 Scale: 1:16  
 Last updated: 12/23/2016

56641-10