



Product & Packaging Specs

24" 2-3/8 Dia Post Anchor (IS-600)

Item #: 30060

ITEM NO.	QTY.	PART NUMBER	DESCRIPTION
1	1	30060-11	Weldment, Base Anchor
2	1	30060-13	Base, Post Anchor Steel
3	1	30060-14	Cap, Post Anchor Steel

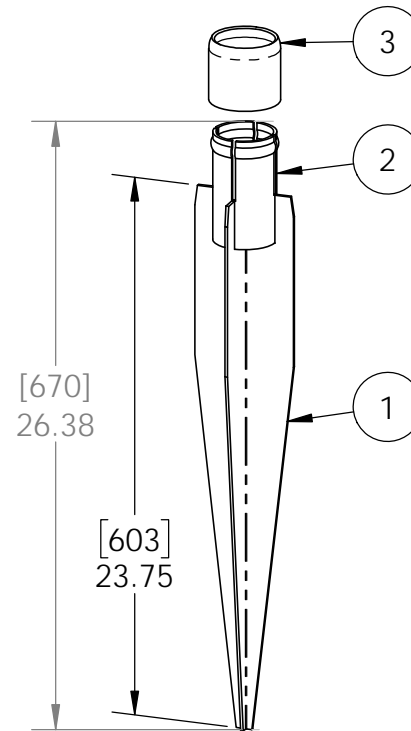
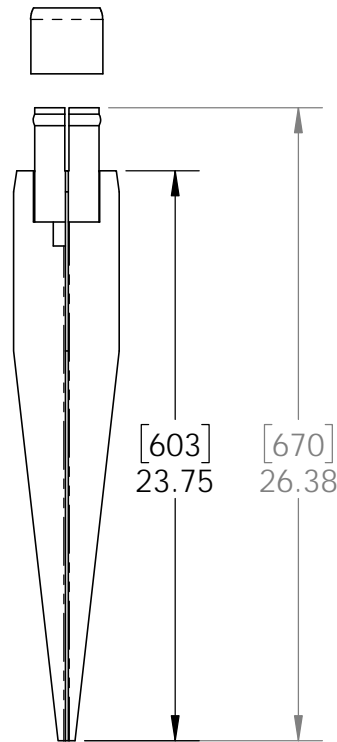
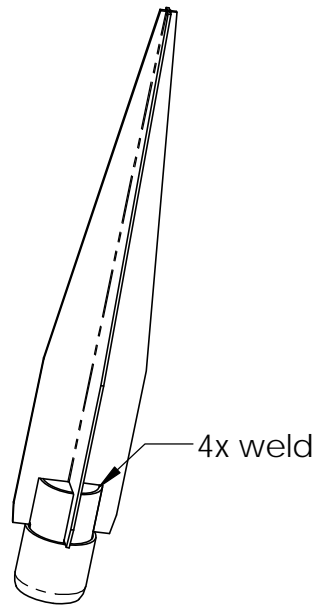

Weight: 7.09 LBS
Scale: 1:8
Last updated: 10/14/2016

30060-10



Product & Packaging Specs

24" 2-3/8 Dia Post Anchor (IS-600)

Item #: 30060

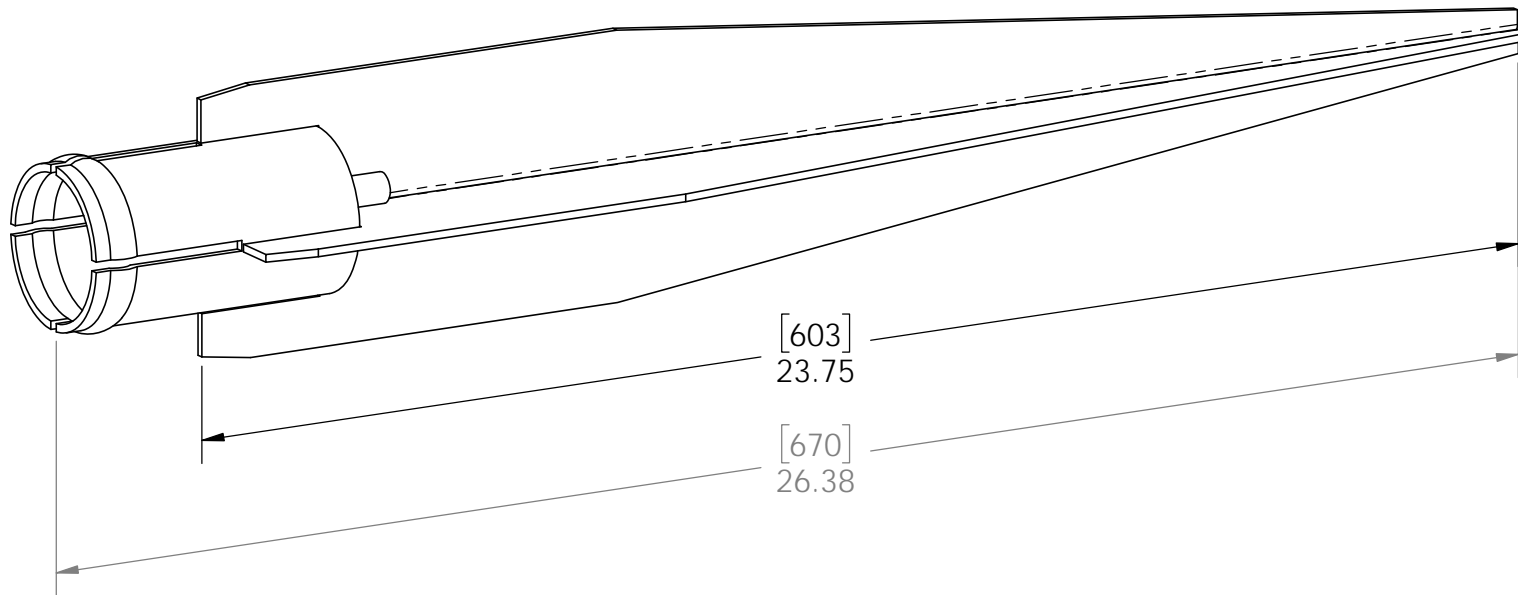

Weight: 7.09 LBS
Scale: 1:3
Last updated: 10/14/2016

30060-10



Product & Packaging Specs

24" 2-3/8 Dia Post Anchor (IS-600)

Item #: 30060

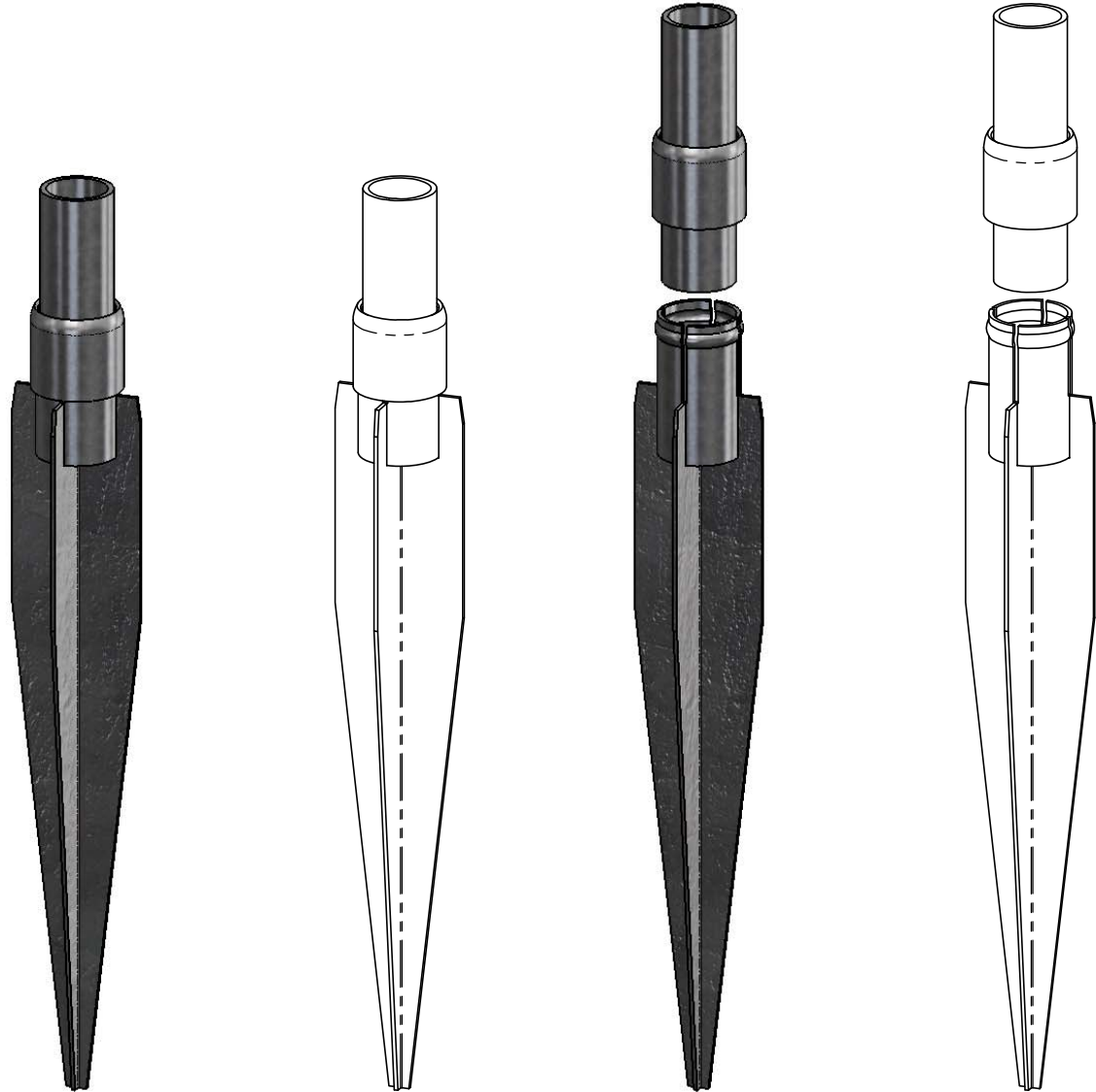
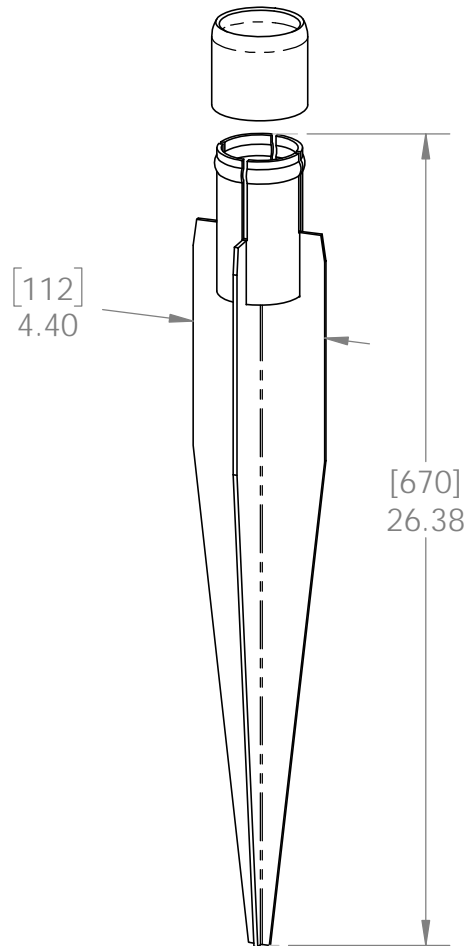

Weight: 7.09 LBS
Scale: 1:6
Last updated: 10/14/2016

30060-10



instant post holes

OZCO BUILDING PRODUCTS ■■■

Product & Packaging Specs

24" 2-3/8 Dia Post Anchor (IS-600)

Item #: Typical Installation

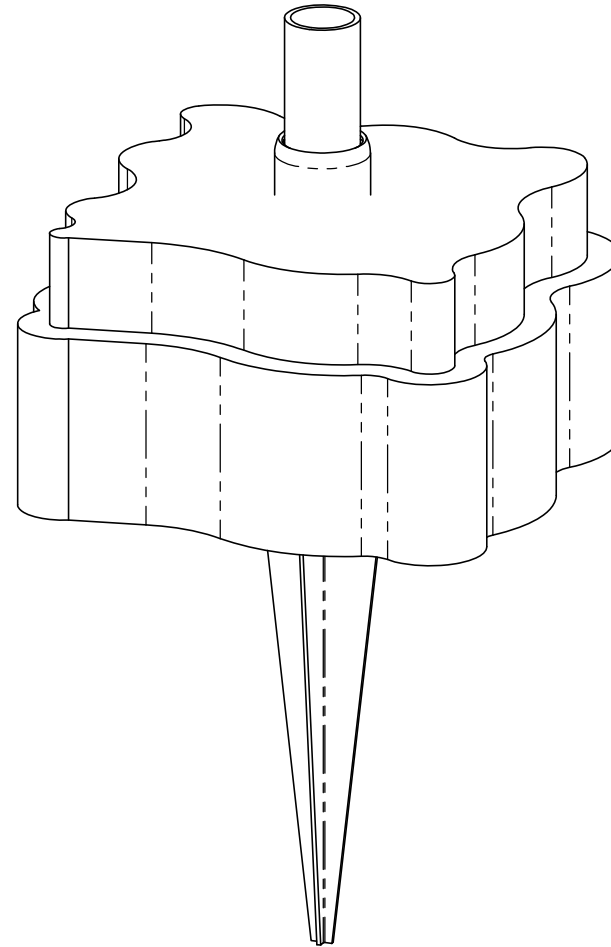
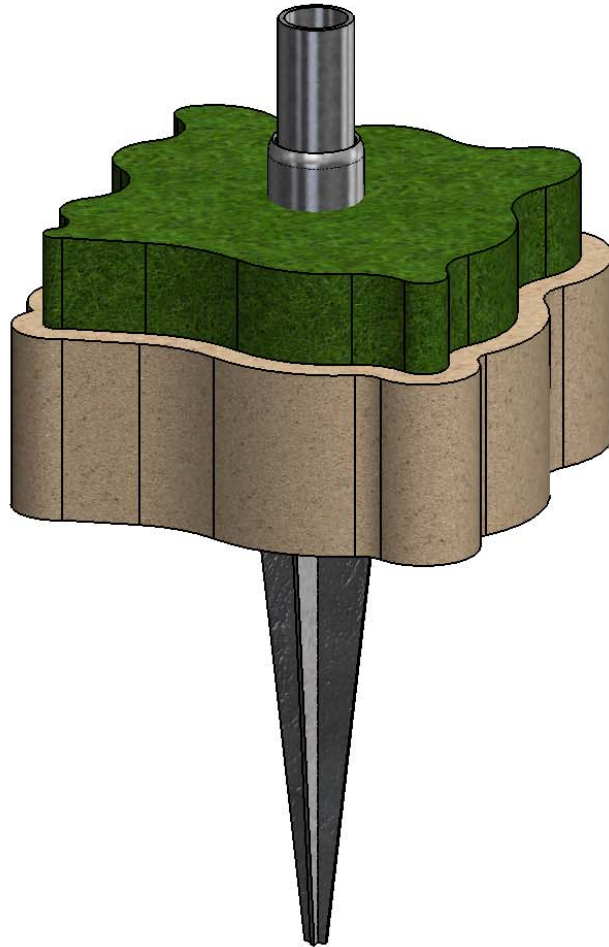

Weight: 7.09 LBS
Scale: 1:6
Last updated: 10/14/2016

30060-10

V2.00 - Installation Instructions, Specifications and Project Plans are effective 10/14/2016 . This information is updated periodically and should not be relied upon after 2 years from 10/14/2016 . Please visit OZCOBP.com to get current information. 4



Product & Packaging Specs

Case, 30060

Item #: Case

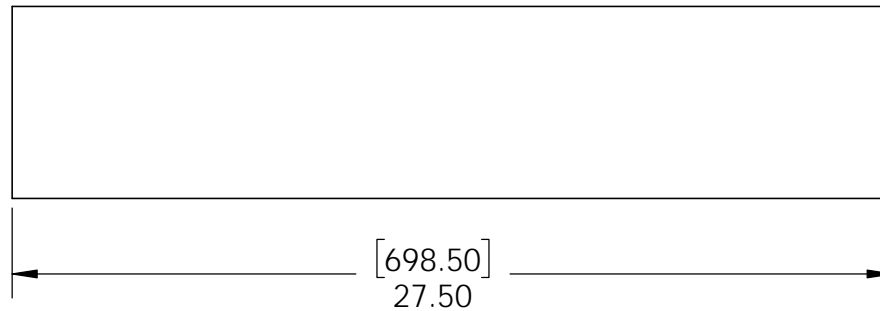
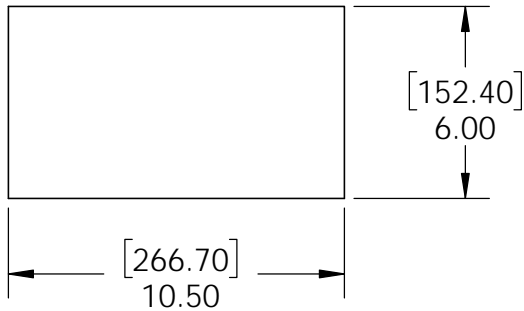
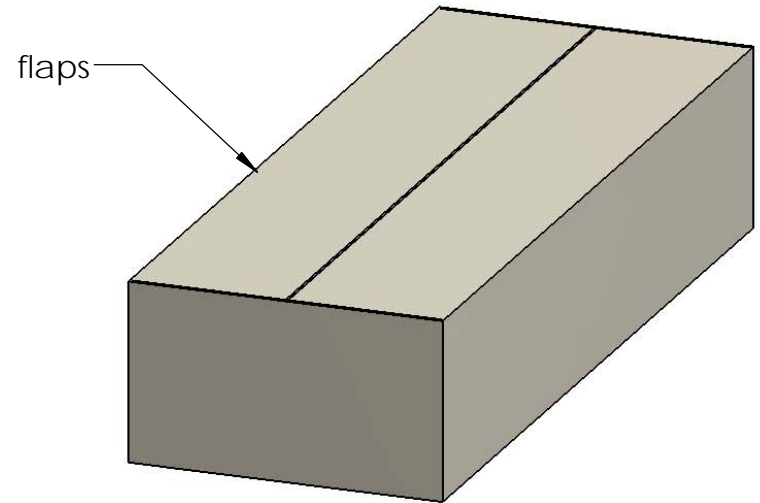

Material: Corrugated Paper
 Finish: See artwork
 Weight: 0.46 LBS
 Scale: 1:6
 Last updated: 10/14/2016

30060-10



Product & Packaging Specs

30060 Packing
Item #: Case packing

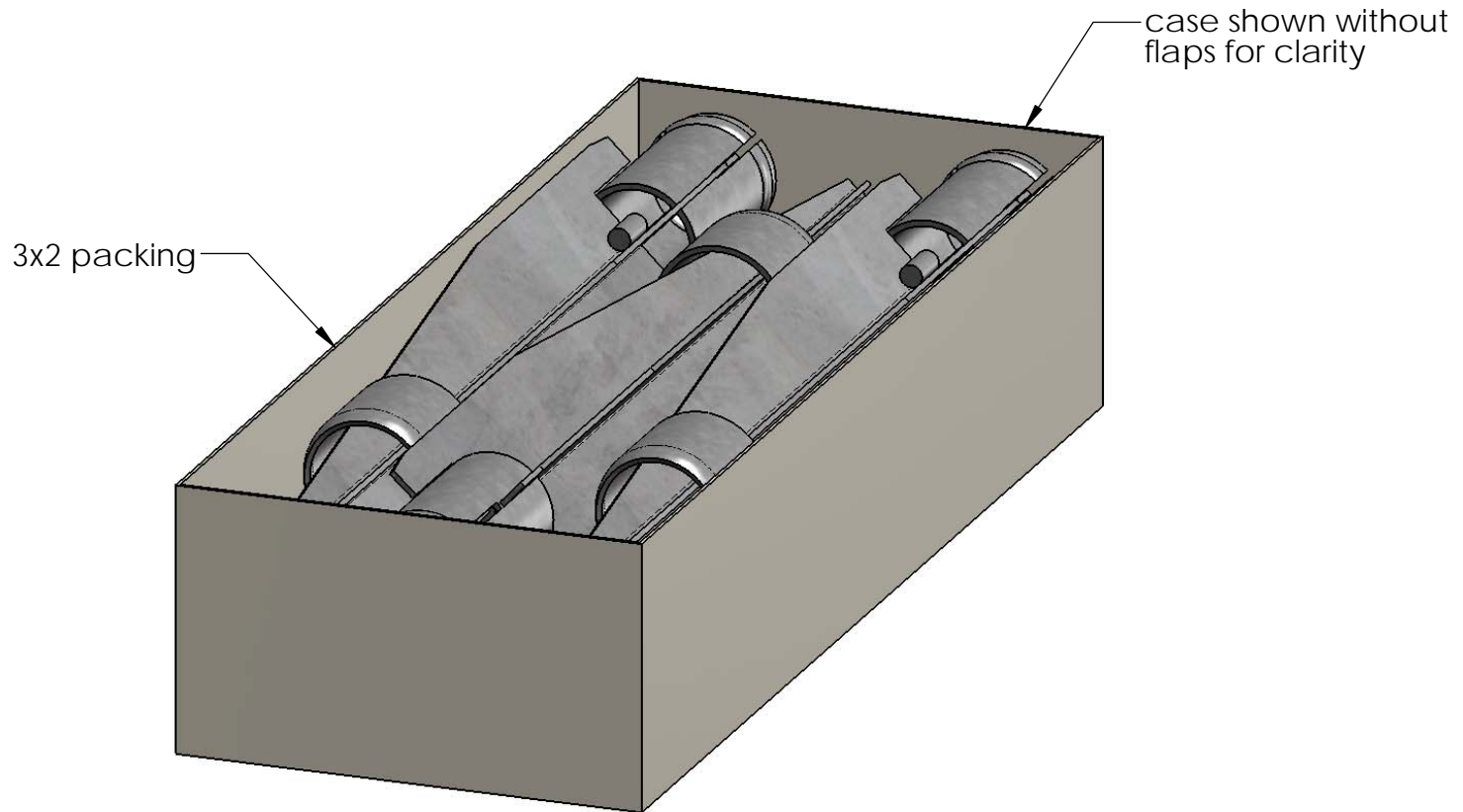

Weight: 42.90 LBS
Scale: 1:4
Last updated: 10/14/2016

30060-10



Product & Packaging Specs

30060 Packing

Item #: Pallet packing

Item #: **30060** | **IS-600**

IS-600 (2 3/8" Round) Steel

PALLET 120 pcs

SKU#: **30062**



Weight: 838 lbs

LOT# Priority#

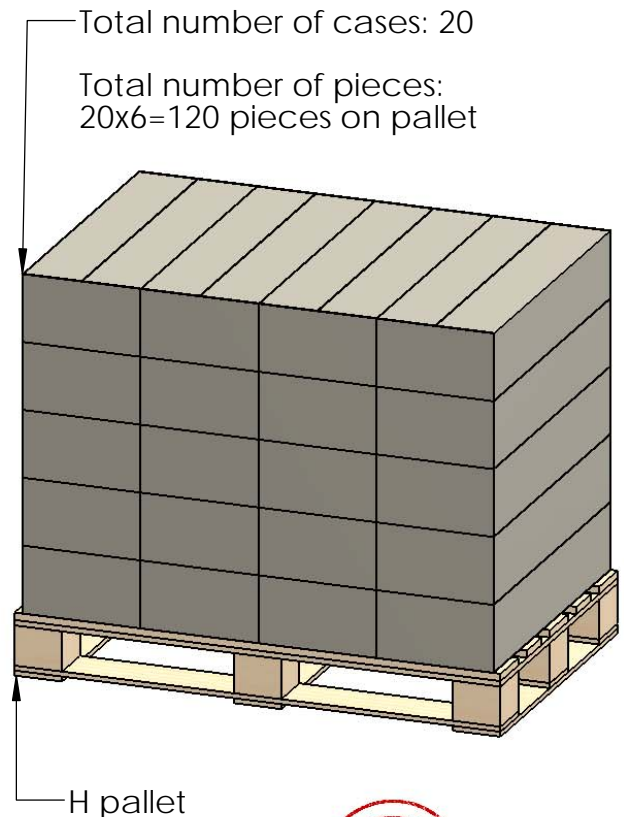
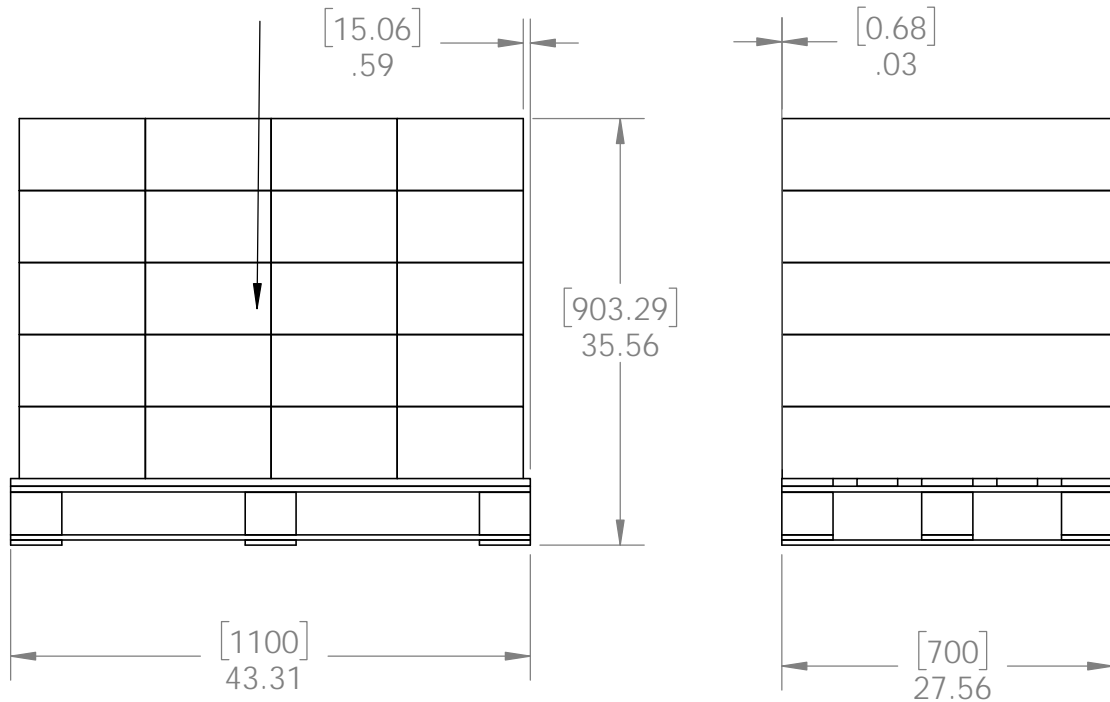

additional pallet packing instructions

- plywood on top layer
- strap to pallet
- clear wrap around boxes

Weight: 838 LBS
 Scale: 1:16
 Last updated: 10/14/2016

30060-10